

# INTERNATIONAL STANDARD



---

## Wind turbines – Part 11: Acoustic noise measurement techniques





**THIS PUBLICATION IS COPYRIGHT PROTECTED**  
**Copyright © 2012 IEC, Geneva, Switzerland**

All rights reserved. Unless otherwise specified, no part of this publication may be reproduced or utilized in any form or by any means, electronic or mechanical, including photocopying and microfilm, without permission in writing from either IEC or IEC's member National Committee in the country of the requester.

If you have any questions about IEC copyright or have an enquiry about obtaining additional rights to this publication, please contact the address below or your local IEC member National Committee for further information.

IEC Central Office  
3, rue de Varembe  
CH-1211 Geneva 20  
Switzerland

Tel.: +41 22 919 02 11  
Fax: +41 22 919 03 00  
[info@iec.ch](mailto:info@iec.ch)  
[www.iec.ch](http://www.iec.ch)

### **About the IEC**

The International Electrotechnical Commission (IEC) is the leading global organization that prepares and publishes International Standards for all electrical, electronic and related technologies.

### **About IEC publications**

The technical content of IEC publications is kept under constant review by the IEC. Please make sure that you have the latest edition, a corrigenda or an amendment might have been published.

#### **Useful links:**

IEC publications search - [www.iec.ch/searchpub](http://www.iec.ch/searchpub)

The advanced search enables you to find IEC publications by a variety of criteria (reference number, text, technical committee,...).

It also gives information on projects, replaced and withdrawn publications.

IEC Just Published - [webstore.iec.ch/justpublished](http://webstore.iec.ch/justpublished)

Stay up to date on all new IEC publications. Just Published details all new publications released. Available on-line and also once a month by email.

Electropedia - [www.electropedia.org](http://www.electropedia.org)

The world's leading online dictionary of electronic and electrical terms containing more than 30 000 terms and definitions in English and French, with equivalent terms in additional languages. Also known as the International Electrotechnical Vocabulary (IEV) on-line.

Customer Service Centre - [webstore.iec.ch/csc](http://webstore.iec.ch/csc)

If you wish to give us your feedback on this publication or need further assistance, please contact the Customer Service Centre: [csc@iec.ch](mailto:csc@iec.ch).



IEC 61400-11

Edition 3.0 2012-11

# INTERNATIONAL STANDARD



---

## Wind turbines – Part 11: Acoustic noise measurement techniques

INTERNATIONAL  
ELECTROTECHNICAL  
COMMISSION

PRICE CODE

**XA**

---

ICS 27.180

ISBN 978-2-83220-463-4

**Warning! Make sure that you obtained this publication from an authorized distributor.**

## CONTENTS

FOREWORD.....	5
INTRODUCTION.....	7
1 Scope.....	8
2 Normative references .....	8
3 Terms and definitions .....	9
4 Symbols and units .....	12
5 Outline of method .....	13
6 Instrumentation .....	14
6.1 Acoustic instruments .....	14
6.1.1 General .....	14
6.1.2 Equipment for the determination of the equivalent continuous A-weighted sound pressure level.....	14
6.1.3 Equipment for the determination of A-weighted 1/3-octave band spectra .....	14
6.1.4 Equipment for the determination of narrow band spectra .....	14
6.1.5 Microphone with measurement board and windscreen .....	14
6.1.6 Acoustical calibrator .....	16
6.1.7 Data recording/playback systems .....	16
6.2 Non-acoustic Instruments .....	16
6.2.1 General .....	16
6.2.2 Anemometers .....	16
6.2.3 Electric power transducer .....	17
6.2.4 Other instrumentation .....	17
6.3 Traceable calibration .....	17
7 Acoustic measurements and measurement procedures .....	17
7.1 Acoustic measurement positions .....	17
7.2 Acoustic measurements .....	20
7.2.1 General .....	20
7.2.2 Acoustic measurement requirements .....	20
7.2.3 A-weighted sound pressure level .....	21
7.2.4 A-weighted 1/3-octave band measurements.....	21
7.2.5 A-weighted narrow band measurements .....	21
7.2.6 Optional acoustic measurements at positions 2, 3 and 4.....	21
7.2.7 Other optional measurements .....	21
8 Non-acoustic measurements .....	21
8.1 General.....	21
8.2 Wind speed measurements .....	22
8.2.1 Determination of the wind speed during wind turbine operation.....	22
8.2.2 Wind speed measurements during background noise measurements.....	23
8.3 Downwind direction .....	24
8.4 Other atmospheric conditions .....	24
8.5 Rotor speed and pitch angle measurement.....	24
9 Data reduction procedures.....	24
9.1 General methodology for sound power levels and 1/3-octave band levels.....	24
9.2 Calculation of sound pressure levels .....	27

9.2.1	General .....	27
9.2.2	Calculation of average sound spectra and uncertainty per bin .....	27
9.2.3	Calculation of average wind speed and uncertainty per bin .....	29
9.2.4	Calculation of noise levels at bin centres including uncertainty .....	30
9.3	Apparent sound power levels.....	31
9.4	Apparent sound power levels with reference to wind speed in 10 m height .....	32
9.5	Tonal audibility .....	33
9.5.1	General methodology for tonality .....	33
9.5.2	Identifying possible tones .....	34
9.5.3	Classification of spectral lines within the critical band.....	34
9.5.4	Identified tone .....	37
9.5.5	Determination of the tone level .....	37
9.5.6	Determination of the masking noise level.....	37
9.5.7	Determination of tonality.....	37
9.5.8	Determination of audibility .....	38
9.5.9	Background noise .....	38
10	Information to be reported .....	39
10.1	General .....	39
10.2	Characterisation of the wind turbine .....	39
10.3	Physical environment .....	39
10.4	Instrumentation .....	40
10.5	Acoustic data .....	40
10.6	Non-acoustic data .....	41
10.7	Uncertainty.....	41
Annex A (informative)	Other possible characteristics of wind turbine noise emission and their quantification .....	42
Annex B (informative)	Assessment of turbulence intensity .....	44
Annex C (informative)	Assessment of measurement uncertainty .....	45
Annex D (informative)	Apparent roughness length .....	47
Annex E (informative)	Characterization of a secondary wind screen.....	49
Annex F (normative)	Small wind turbines .....	53
Annex G (informative)	Air absorption .....	57
Bibliography.....		58
Figure 1 – Mounting of the microphone .....		15
Figure 2 – Picture of microphone and measurement board.....		16
Figure 3 – Standard pattern for microphone measurement positions (plan view) .....		18
Figure 4 – Illustration of the definitions of $R_0$ and slant distance $R_1$ .....		19
Figure 5 – Acceptable meteorological mast position (hatched area) .....		22
Figure 6 – Flowchart showing the data reduction procedure.....		26
Figure 7 – Flowchart for determining tonal audibility for each wind speed bin .....		33
Figure 8 – Illustration of $L_{70} \%$ level in the critical band.....		35
Figure 9 – Illustration of lines below the $L_{70} \% + 6$ dB criterion .....		36
Figure 10 – Illustration of $L_{pn,avg}$ level and lines classified as masking.....		36
Figure 11 – Illustration of classifying all spectral lines.....		37
Figure E.1 – Example 1 of a secondary wind screen .....		50

Figure E.2 – Example 2 of secondary wind screen ..... 51

Figure E.3 – Example on insertion loss from Table E.1 ..... 52

Figure F.1 – Allowable region for meteorological mast position as a function of  $\beta$  –  
Plan view ..... 54

Figure F.2 – Example immission noise map ..... 56

Figure G.1 – Example of 1/3-octave spectrum ..... 57

Table C.1 – Examples of possible values of type B uncertainty components relevant  
for apparent sound power spectra ..... 46

Table C.2 – Examples of possible values of type B uncertainty components for wind  
speed determination relevant for apparent sound power spectra ..... 46

Table D.1 – Roughness length ..... 47

Table E.1 – Example on reporting of insertion loss ..... 51

## INTERNATIONAL ELECTROTECHNICAL COMMISSION

## WIND TURBINES –

## Part 11: Acoustic noise measurement techniques

## FOREWORD

- 1) The International Electrotechnical Commission (IEC) is a worldwide organization for standardization comprising all national electrotechnical committees (IEC National Committees). The object of IEC is to promote international co-operation on all questions concerning standardization in the electrical and electronic fields. To this end and in addition to other activities, IEC publishes International Standards, Technical Specifications, Technical Reports, Publicly Available Specifications (PAS) and Guides (hereafter referred to as “IEC Publication(s)”). Their preparation is entrusted to technical committees; any IEC National Committee interested in the subject dealt with may participate in this preparatory work. International, governmental and non-governmental organizations liaising with the IEC also participate in this preparation. IEC collaborates closely with the International Organization for Standardization (ISO) in accordance with conditions determined by agreement between the two organizations.
- 2) The formal decisions or agreements of IEC on technical matters express, as nearly as possible, an international consensus of opinion on the relevant subjects since each technical committee has representation from all interested IEC National Committees.
- 3) IEC Publications have the form of recommendations for international use and are accepted by IEC National Committees in that sense. While all reasonable efforts are made to ensure that the technical content of IEC Publications is accurate, IEC cannot be held responsible for the way in which they are used or for any misinterpretation by any end user.
- 4) In order to promote international uniformity, IEC National Committees undertake to apply IEC Publications transparently to the maximum extent possible in their national and regional publications. Any divergence between any IEC Publication and the corresponding national or regional publication shall be clearly indicated in the latter.
- 5) IEC itself does not provide any attestation of conformity. Independent certification bodies provide conformity assessment services and, in some areas, access to IEC marks of conformity. IEC is not responsible for any services carried out by independent certification bodies.
- 6) All users should ensure that they have the latest edition of this publication.
- 7) No liability shall attach to IEC or its directors, employees, servants or agents including individual experts and members of its technical committees and IEC National Committees for any personal injury, property damage or other damage of any nature whatsoever, whether direct or indirect, or for costs (including legal fees) and expenses arising out of the publication, use of, or reliance upon, this IEC Publication or any other IEC Publications.
- 8) Attention is drawn to the Normative references cited in this publication. Use of the referenced publications is indispensable for the correct application of this publication.
- 9) Attention is drawn to the possibility that some of the elements of this IEC Publication may be the subject of patent rights. IEC shall not be held responsible for identifying any or all such patent rights.

International Standard IEC 61400-11 has been prepared by IEC technical committee 88: Wind turbines.

This third edition of IEC 61400-11 cancels and replaces the second edition published in 2002 and its Amendment 1 (2006). It constitutes a technical revision, introducing new principles for data reduction procedures.

The text of this standard is based on the following documents:

FDIS	Report on voting
88/436/FDIS	88/440/RVD

Full information on the voting for the approval of this standard can be found in the report on voting indicated in the above table.

This publication has been drafted in accordance with the ISO/IEC Directives, Part 2.

A list of all parts of the IEC 61400 series, under the general title *Wind turbines*, can be found on the IEC website.

The committee has decided that the contents of this publication will remain unchanged until the stability date indicated on the IEC web site under "<http://webstore.iec.ch>" in the data related to the specific publication. At this date, the publication will be

- reconfirmed,
- withdrawn,
- replaced by a revised edition, or
- amended.

A bilingual edition of this document may be issued at a later date.

**IMPORTANT – The 'colour inside' logo on the cover page of this publication indicates that it contains colours which are considered to be useful for the correct understanding of its contents. Users should therefore print this document using a colour printer.**

## INTRODUCTION

The purpose of this part of IEC 61400 is to provide a uniform methodology that will ensure consistency and accuracy in the measurement and analysis of acoustical emissions by wind turbine generator systems. This International Standard has been prepared with the anticipation that it would be applied by:

- wind turbine manufacturers striving to meet well defined acoustic emission performance requirements and/or a possible declaration system (e.g. IEC/TS 61400-14);
- wind turbine purchasers for specifying performance requirements;
- wind turbine operators who may be required to verify that stated, or required, acoustic performance specifications are met for new or refurbished units;
- wind turbine planners or regulators who must be able to accurately and fairly define acoustical emission characteristics of a wind turbine in response to environmental regulations or permit requirements for new or modified installations.

This standard provides guidance in the measurement, analysis and reporting of complex acoustic emissions from wind turbine generator systems. The standard will benefit those parties involved in the manufacture, installation, planning and permitting, operation, utilization, and regulation of wind turbines. The measurement and analysis techniques recommended in this document should be applied by all parties to ensure that continuing development and operation of wind turbines is carried out in an atmosphere of consistent and accurate communication relative to environmental concerns. This standard presents measurement and reporting procedures expected to provide accurate results that can be replicated by others.

## WIND TURBINES –

### Part 11: Acoustic noise measurement techniques

#### 1 Scope

This part of IEC 61400 presents measurement procedures that enable noise emissions of a wind turbine to be characterised. This involves using measurement methods appropriate to noise emission assessment at locations close to the machine, in order to avoid errors due to sound propagation, but far away enough to allow for the finite source size. The procedures described are different in some respects from those that would be adopted for noise assessment in community noise studies. They are intended to facilitate characterisation of wind turbine noise with respect to a range of wind speeds and directions. Standardisation of measurement procedures will also facilitate comparisons between different wind turbines.

The procedures present methodologies that will enable the noise emissions of a single wind turbine to be characterised in a consistent and accurate manner. These procedures include the following:

- location of acoustic measurement positions;
- requirements for the acquisition of acoustic, meteorological, and associated wind turbine operational data;
- analysis of the data obtained and the content for the data report; and
- definition of specific acoustic emission parameters, and associated descriptors which are used for making environmental assessments.

This International Standard is not restricted to wind turbines of a particular size or type. The procedures described in this standard allow for the thorough description of the noise emission from a wind turbine. A method for small wind turbines is described in Annex F.

#### 2 Normative references

The following documents, in whole or in part, are normatively referenced in this document and are indispensable for its application. For dated references, only the edition cited applies. For undated references, the latest edition of the referenced document (including any amendments) applies.

IEC 60688, *Electrical measuring transducers for converting a.c. electrical quantities to analogue or digital signals*

IEC 60942:2003, *Electroacoustics – Sound calibrators*

IEC 61260:1995, *Electroacoustics – Octave-band and fractional-octave-band filters*

IEC 61400-12-1:2005, *Wind turbines – Part 12-1: Power performance measurements of electricity producing wind turbines*

IEC 61400-12-2, *Wind turbines – Part 12-2: Power performance verification of electricity producing wind turbines*<sup>1</sup>

---

<sup>1</sup> To be published.

IEC 61672 (all parts), *Electroacoustics – Sound level meters*

ISO/IEC Guide 98-3, *Uncertainty of measurement – Part 3: Guide to the expression of uncertainty in measurement (GUM:1995)*

### 3 Terms and definitions

For the purposes of this standard, the following terms and definitions apply.

#### 3.1

##### apparent sound power level

$L_{WA}$

A-weighted sound power level re. 1 pW of a point source at the rotor centre with the same emission in the downwind direction as the wind turbine being measured,  $L_{WA}$  is determined at bin centre wind speeds at hub height

Note 1 to entry: Apparent sound power level is expressed in dB re. 1 pW.

#### 3.2

##### apparent sound power level with reference to wind speed at 10 m height

$L_{WA,10m}$

A-weighted sound power level re. 1 pW of a point source at the rotor centre with the same emission in the downwind direction as the wind turbine being measured,  $L_{WA,10m}$  are determined at bin centre wind speeds at 10 m height within the measured wind speed range

Note 1 to entry: Apparent sound power level with reference to wind speed at 10 m height is expressed in dB re. 1 pW.

#### 3.3

##### audibility criterion

$L_a$

frequency dependent criterion curve determined from listening tests, and reflecting the subjective response of a “typical” listener to tones of different frequencies

Note 1 to entry: Audibility criterion is expressed in dB re. 20  $\mu$ Pa.

#### 3.4 sound pressure levels

##### 3.4.1 A-weighted sound pressure levels

$L_A$

sound pressure levels measured with the A frequency weighting networks specified in IEC 61672

Note 1 to entry: A-weighted sound pressure levels are expressed in dB re. 20  $\mu$ Pa.

##### 3.4.2 C-weighted sound pressure levels

$L_C$

sound pressure levels measured with the C frequency weighting networks specified in IEC 61672

Note 1 to entry: C-weighted sound pressure levels are expressed in dB re. 20  $\mu$ Pa.

#### 3.5

##### bin centre

centre value of a wind speed bin

### 3.6 inclination angle

 $\phi$ 

angle between the plane of the measurement board and a line from the microphone to the rotor centre

Note 1 to entry: Inclination angle is expressed in °.

### 3.7 maximum power

maximum value of the binned power curve for the power optimised mode of operation

Note 1 to entry: Maximum power is expressed in kW.

### 3.8 measured wind speed at height $Z$

 $V_{Z,m}$ 

wind speed measured at height  $Z$  with a mast mounted anemometer

Note 1 to entry: Measured wind speed at height  $Z$  is expressed in m/s.

### 3.9 measured nacelle wind speed at hub height

 $V_{nac,m}$ 

wind speed measured at hub height with a nacelle anemometer

Note 1 to entry: Measured nacelle wind speed at hub height is expressed in m/s.

### 3.10 normalised nacelle wind speed at hub height

 $V_{nac,n}$ 

normalised wind speed measured at hub height with a nacelle anemometer corrected to standard meteorological conditions

Note 1 to entry: Normalised nacelle wind speed at hub height is expressed in m/s.

### 3.11 normalised wind speed derived from power curve

 $V_{P,n}$ 

normalised wind speed derived from power curve under standard meteorological conditions

Note 1 to entry: Normalised wind speed derived from power curve is expressed in m/s.

### 3.12 normalised wind speed at hub height during background noise measurements

 $V_{B,n}$ 

normalised wind speed at hub height from anemometer

Note 1 to entry: Normalised wind speed at hub height during background noise measurements is expressed in m/s.

### 3.13 normalised wind speed at hub height

 $V_{H,n}$ 

normalised wind speed at hub height

Note 1 to entry: Normalised wind speed at hub height is expressed in m/s.

### 3.14 normalised wind speed at height $Z$

 $V_{Z,n}$ 

normalised wind speed at height  $Z$  from mast mounted anemometer

Note 1 to entry: Normalised wind speed at height  $Z$  is expressed in m/s.

### 3.15 reference distance

$R_0$

nominal horizontal distance from the centre of the base of the wind turbine to each of the prescribed microphone positions

Note 1 to entry: Reference distance is expressed in m.

### 3.16 reference roughness length

$z_{0\text{ref}}$

roughness length of 0,05 m used for converting wind speed to meteorological reference conditions

Note 1 to entry: Reference roughness length is expressed in m.

### 3.17 sound pressure level

$L_p$

10 times the  $\log_{10}$  of the ratio of the square mean sound pressure to the square of the reference sound pressure of 20  $\mu\text{Pa}$

Note 1 to entry: Sound pressure level is expressed in dB re. 20  $\mu\text{Pa}$ .

### 3.18 tonal audibility

$\Delta L_{a,k}$

difference between the tonality and the audibility criterion in each wind speed bin, where  $k$  is the centre value of the wind speed bin

Note 1 to entry: Tonal audibility is expressed in dB.

### 3.19 tonality

$\Delta L_k$

difference between the tone level and the level of the masking noise in the critical band around the tone in each wind speed bin where  $k$  is the centre value of the wind speed bin

Note 1 to entry: Tonality is expressed in dB.

### 3.20 wind speed bin

wind speed interval, 0,5 m/s wide, centred around integer and half-integer wind speeds open at the low end, and closed at the high end

### 3.21 wind speed at 10 m height

$V_{10}$

wind speed at 10 m height for reporting apparent sound power levels and spectra with reference to 10 m height

Note 1 to entry: Wind speed at 10 m height is expressed in m/s.

## 4 Symbols and units

$D$	rotor diameter (horizontal axis turbine) or equatorial diameter (vertical axis turbine)	(m)
$H$	height of rotor centre (horizontal axis turbine) or height of rotor equatorial plane (vertical axis turbine) above local ground near the wind turbine	(m)
$L_A$ or $L_C$	A or C-weighted sound pressure level	(dB)
$L_{Aeq}$	equivalent continuous A-weighted sound pressure level	(dB)
$L_{pn,j,k}$	sound pressure level of masking noise within a critical band in the “ $j^{\text{th}}$ ” spectra at the “ $k^{\text{th}}$ ” wind speed bin	(dB)
$L_{pn,avg,j,k}$	average of analysis bandwidth sound pressure levels of masking noise in the “ $j^{\text{th}}$ ” spectra at the “ $k^{\text{th}}$ ” wind speed bin	(dB)
$L_{pt,j,k}$	sound pressure level of the tone or tones in the “ $j^{\text{th}}$ ” spectra at the “ $k^{\text{th}}$ ” wind speed bin	(dB)
$L_{WA,k}$	apparent sound power level, where $k$ is a wind speed bin centre value	(dB)
log	logarithm to base 10	
$P_m$	measured electric power	(kW)
$P_n$	normalised electric power	(kW)
$R_1$	slant distance, from rotor centre to actual measurement position	(m)
$R_0$	reference distance	(m)
$S_0$	reference area, $S_0 = 1 \text{ m}^2$	(m <sup>2</sup> )
$T_C$	air temperature	(°C)
$T_K$	absolute air temperature	(K)
$U_A$	type A uncertainty	(-)
$U_B$	type B uncertainty	(-)
$V_H$	wind speed at hub height, $H$	(m/s)
$V_P$	derived wind speed from power curve	(m/s)
$V_z$	wind speed at height, $z$	(m/s)
$V_{nac}$	wind speed from nacelle anemometer	(m/s)
$f$	frequency of the tone	(Hz)
$f_c$	centre frequency of critical band	(Hz)
$p$	atmospheric pressure	(kPa)
$z_0$	roughness length	(m)
$z_{0ref}$	reference roughness length, 0,05 m	(m)

$z$	anemometer height	(m)
$\kappa$	ratio of normalised wind speed and measured wind speed	(-)
$\Delta L_{tn,j,k}$	tonality of the “ $j^{\text{th}}$ ” spectra at “ $k^{\text{th}}$ ” wind speed	(dB)
$\phi$	inclination angle	(°)

## 5 Outline of method

This part of IEC 61400 defines the procedures to be used in the measurement, analysis and reporting of acoustic emissions of a wind turbine. Instrumentation and calibration requirements are specified to ensure accuracy and consistency of acoustic and non-acoustic measurements. Non-acoustic measurements required defining the atmospheric conditions relevant to determining the acoustic emissions are also specified. All parameters to be measured and reported are identified, as are the data reduction methods required for obtaining these parameters.

Application of the method described in this International Standard provides the apparent A-weighted sound power levels, spectra, and tonal audibility at bin centre wind speeds at hub height and 10 m height of an individual wind turbine. The tonal audibility is included to give information on the presence of tones in the noise. The tonality determined is not giving information on the tonality at other distances. Optionally, measurements can be made in supplementary positions to give information on the directional characteristics.

The method applies to all wind speeds. The wind speed range for documentation is related to the specific wind turbine. As a minimum it is defined as the hub height wind speed from 0,8 to 1,3 times the wind speed at 85 % of maximum power rounded to bin centres. Indicatively, this is a wind speed range of approximately 6 to 10 m/s at 10 m height, depending on the turbine type. The wind speed range may be expanded for instance to comply with national requirements.

The measurements are made at locations close to the turbine in order to minimise the influence of terrain effects, atmospheric conditions or wind-induced noise. To account for the size of the wind turbine under test, a reference distance  $R_0$  based on the wind turbine dimensions is used.

Measurements are taken with a microphone positioned on a measurement board placed on the ground to reduce the wind noise generated at the microphone and to minimise the influence of different ground types.

Measurements of sound pressure levels, sound pressure spectra, wind speeds, electrical power, rotor rotational speed and, if measured, pitch angle are made simultaneously over short periods of time and over a wide range of hub height wind speeds. The sound pressure levels and spectra at bin centre wind speeds are determined and used for calculating the apparent A-weighted sound power spectra and levels.

Annexes are included that cover:

- other possible characteristics of wind turbine noise emission and their quantification (Annex A informative);
- assessment of turbulence intensity (Annex B informative);
- assessment of measurement uncertainty (Annex C informative);
- apparent roughness length (Annex D informative);
- classification of a secondary wind screen (Annex E informative);
- small wind turbines (Annex F normative);

- air absorption (Annex G informative).

## **6 Instrumentation**

### **6.1 Acoustic instruments**

#### **6.1.1 General**

The following equipment is necessary to perform the acoustic measurements as set forth in this standard.

#### **6.1.2 Equipment for the determination of the equivalent continuous A-weighted sound pressure level**

The equipment shall meet the requirements of an IEC 61672 class 1 sound level meter. The diameter of the microphone diaphragm shall be no greater than 13 mm.

#### **6.1.3 Equipment for the determination of A-weighted 1/3-octave band spectra**

In addition to the requirements given for class 1 sound level meters, the equipment shall have a constant frequency response over at least the frequency range given by the 1/3-octave bands with centre frequencies from 20 Hz to 10 kHz. The filters shall meet the requirements of IEC 61260 for class 1 filters.

The equivalent A-weighted continuous sound pressure levels in 1/3-octave bands with centre frequencies from 20 Hz to 10 kHz shall be determined simultaneously.

#### **6.1.4 Equipment for the determination of narrow band spectra**

The equipment shall fulfil the relevant requirements for IEC 61672 series class 1 instrumentation in the 20 Hz to 11 200 Hz frequency range.

#### **6.1.5 Microphone with measurement board and windscreen**

The microphone shall be mounted at the centre of a flat hard board with the diaphragm of the microphone in a plane normal to the board and with the axis of the microphone pointing towards the wind turbine, as in Figure 1 and Figure 2. The measurement board shall be circular with a diameter of at least 1,0 m and made from material that is acoustically hard, such as plywood or hard chip-board with a thickness of at least 12,0 mm or metal with a thickness of at least 2,5 mm. In the exceptional case that the board is split (i.e. not in one piece) there are considerations; the pieces shall be level within the same plane, the gap less than 1 mm, and the split shall be off the centre line and parallel with the microphone axis as shown in Figure 1a.

The windscreen to be used with the ground-mounted microphone shall consist of a primary and, where necessary, a secondary windscreen. The primary windscreen shall consist of one half of an open cell foam sphere with a diameter of approximately 90 mm, which is centred around the diaphragm of the microphone, as in Figure 2.

The secondary windscreen may be used when it is necessary to obtain an adequate signal-to-noise ratio at low frequencies in high winds.

If the secondary windscreen is used, the influence of the secondary windscreen on the frequency response shall be documented and corrected for in 1/3-octave bands. A procedure for calibration of the secondary windscreen can be found in Annex E together with suggestions for design and demands on the insertion loss.

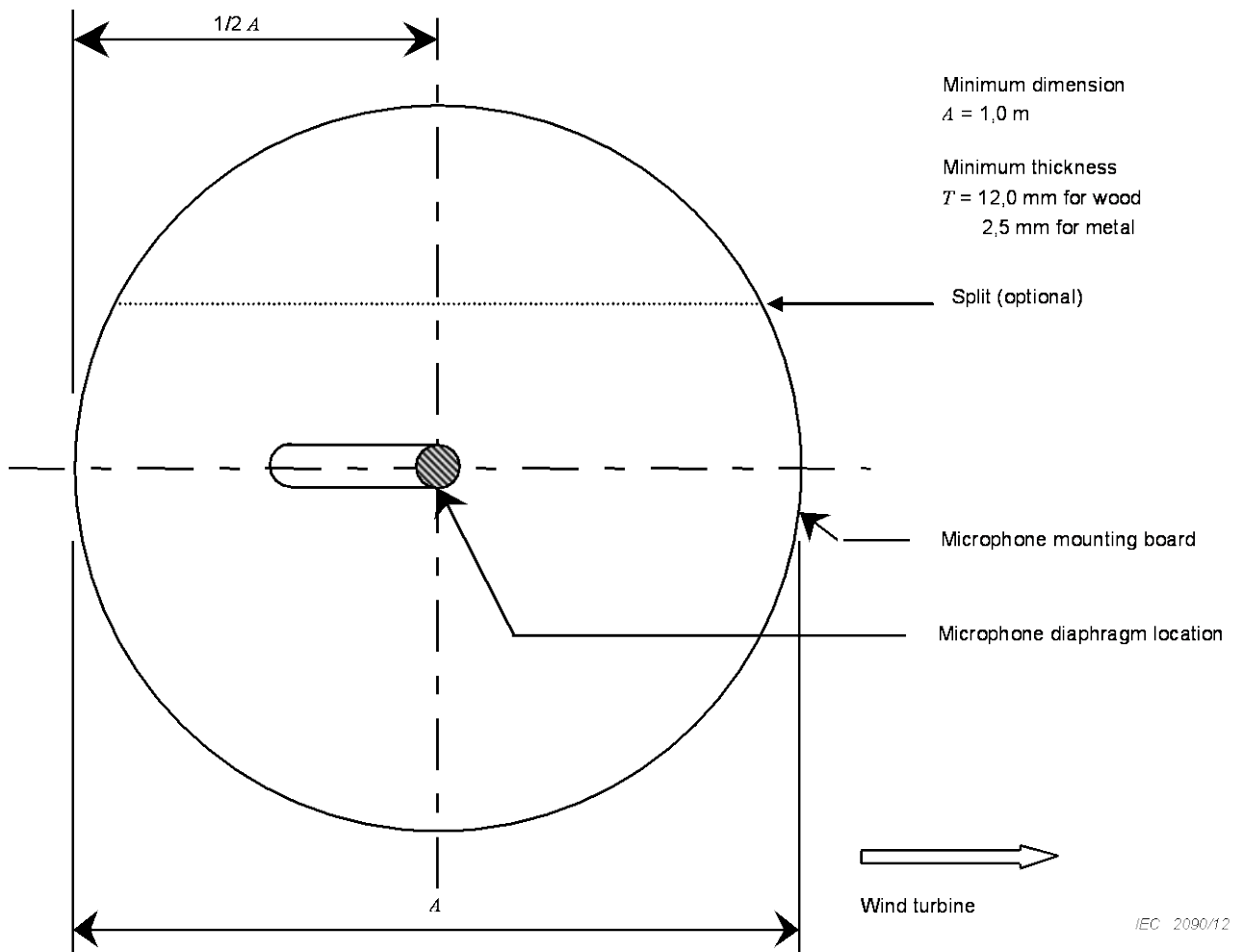

Figure 1a – Mounting of the microphone – Plan view

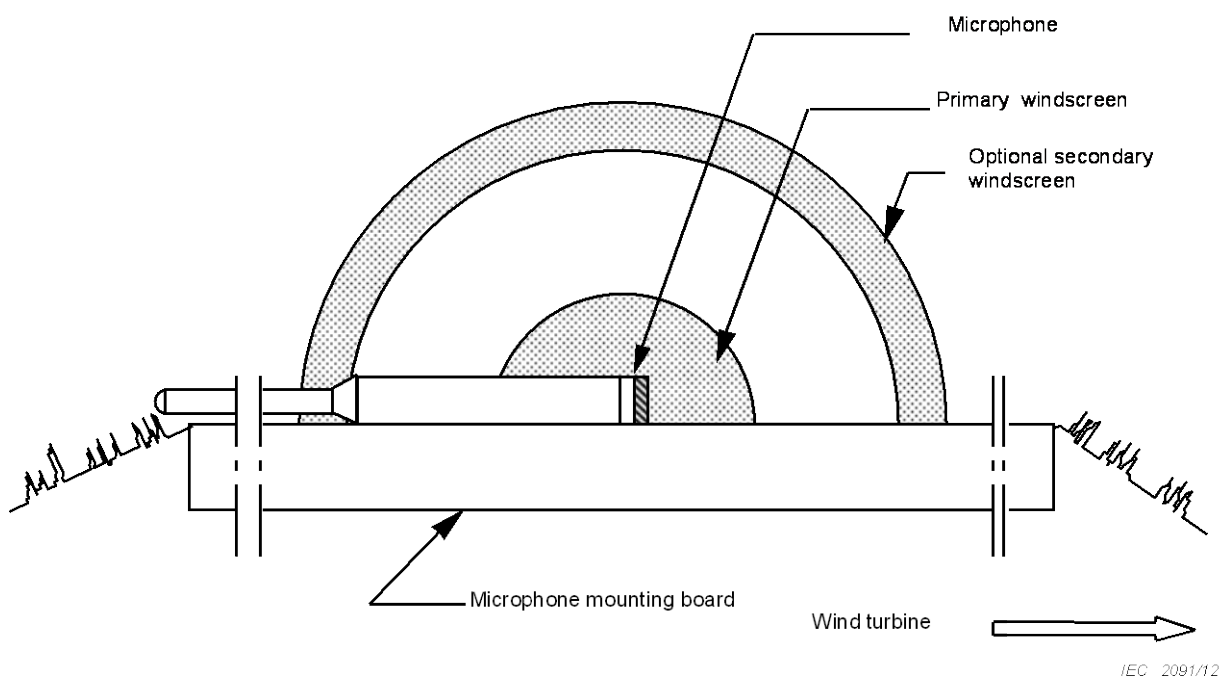

Figure 1b – Mounting of the microphone – Vertical cross-section

Figure 1 – Mounting of the microphone



IEC 2092/12

**Figure 2 – Picture of microphone and measurement board**

#### **6.1.6 Acoustical calibrator**

The complete sound measurement system, including any recording, data logging or computing systems, shall be calibrated immediately before and after the measurement session at one or more frequencies using an acoustical calibrator on the microphone. The calibrator shall fulfil the requirements of IEC 60942:2003 class 1, and shall be used within its specified environmental conditions.

#### **6.1.7 Data recording/playback systems**

A data recording/playback system is a required part of the measurement instrumentation. If used for analysis (other than re-listening), the entire chain of measurement instruments shall fulfil the relevant requirements of IEC 61672 series, for class 1 instrumentation.

### **6.2 Non-acoustic Instruments**

#### **6.2.1 General**

The following equipment is necessary to perform the non-acoustic measurements set forth in this standard.

#### **6.2.2 Anemometers**

The mast mounted anemometer and its signal processing equipment shall have a maximum deviation from the calibration value of  $\pm 0,2$  m/s in the wind speed range from 4 m/s to 12 m/s. It shall be capable of measuring the average wind speed over time intervals synchronized with the acoustic measurements.

Because the nacelle anemometer is calibrated in-situ (8.2.1.2) during measurements, the demand for calibration does not apply to the nacelle anemometer. The measurements from the nacelle anemometer may be supplied from the wind turbine control system. The nacelle anemometer shall not be used for background noise measurements.

### 6.2.3 Electric power transducer

The electric power transducer, including current and voltage transformers, shall meet the accuracy requirements of IEC 60688 class 1. If a calibrated system is not available for the power signal, an additional uncertainty of the electrical power shall be included. The power signal may be supplied by the manufacturer if the uncertainty of the measurement chain can be documented by a detailed description of the entire power measurement chain and the corresponding uncertainty components.

### 6.2.4 Other instrumentation

A camera and instruments to measure distance are required. The temperature shall be measured with an accuracy of  $\pm 1$  °C. The atmospheric pressure shall be measured with an accuracy of  $\pm 1$  kPa.

## 6.3 Traceable calibration

The following equipment shall be checked regularly and be calibrated with traceability to a national or primary standards laboratory. The maximum time from the last calibration shall be as stated for each item of equipment:

- acoustic calibrator (12 months);
- microphone (24 months);
- integrating sound level meter (24 months);
- spectrum analyzer (36 months);
- data recording/playback system (24 months), if used for analysis;
- anemometer (24 months);
- electric power transducer (24 months);
- temperature transducer (24 months);
- atmospheric pressure transducer (24 months).

Where temperature and atmospheric pressure measurements are made only to give general information about the meteorological conditions during the measurement, an internal verification of the instrument is sufficient.

An instrument shall always be recalibrated if it has been repaired or is suspected of fault or damage.

## 7 Acoustic measurements and measurement procedures

### 7.1 Acoustic measurement positions

To fully characterize the noise emission of a wind turbine, the following measurement positions are required.

One, and optionally another three, microphone positions are to be used. The positions shall be laid out in a pattern around the vertical centreline of the wind turbine tower as indicated in the plan view shown in Figure 3. The required downwind measurement position is identified as the reference position, as shown in Figure 3. The direction of the positions shall be within  $\pm 15^\circ$  relative to the downwind direction of the wind turbine at the time of measurement. The

downwind direction can be derived from the yaw position. The horizontal distance  $R_0$  from the wind turbine tower vertical centreline to each microphone position shall be as shown in Figure 3, with a tolerance of  $\pm 20\%$ , maximum  $\pm 30$  m, and shall be measured with an accuracy of  $\pm 2\%$ .

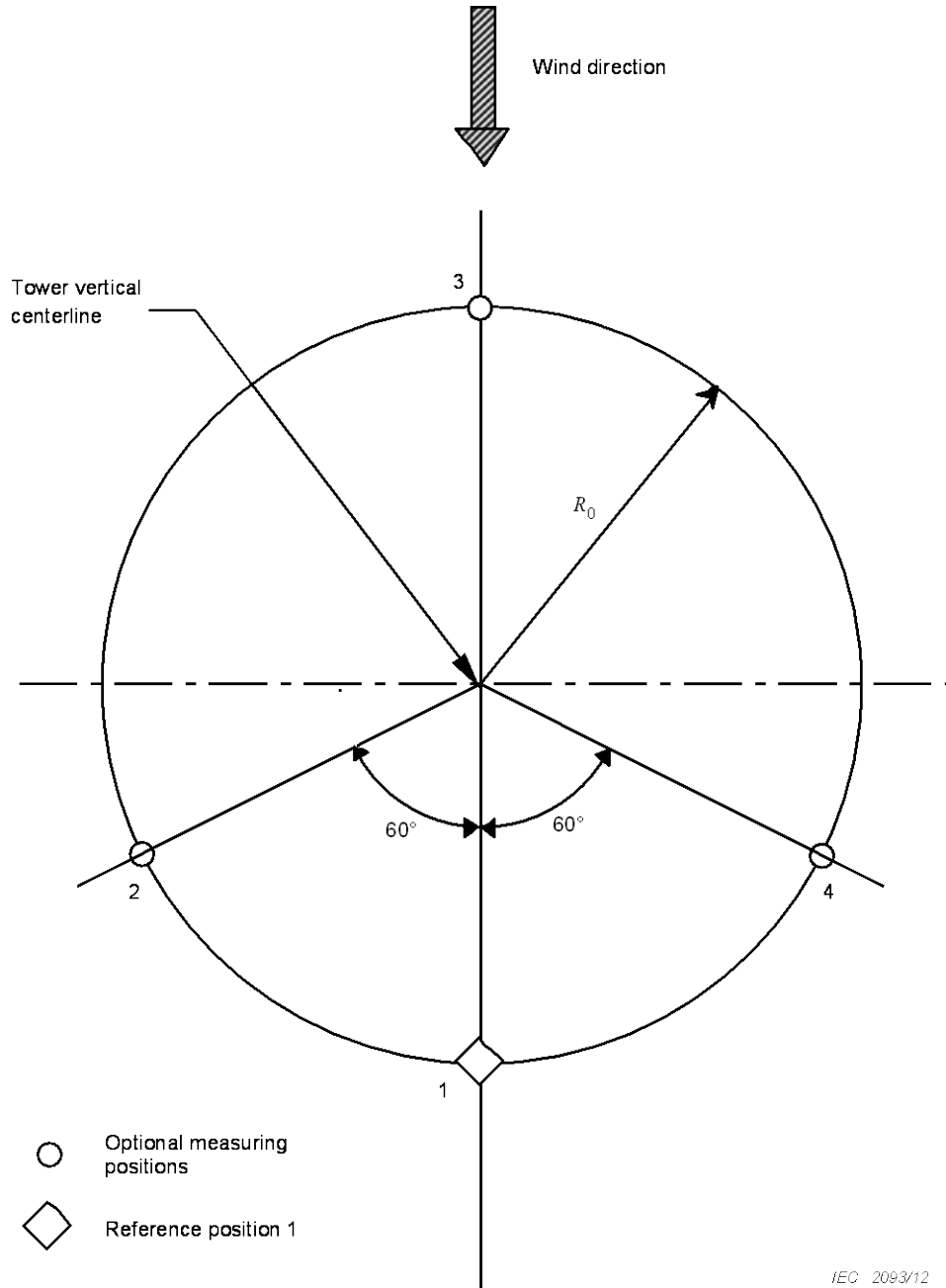

**Figure 3 – Standard pattern for microphone measurement positions (plan view)**

As shown in Figure 4a, the reference distance  $R_0$  for horizontal axis turbines is given by:

$$R_0 = H + \frac{D}{2} \quad (1)$$

where

$H$  is the vertical distance from the ground to the rotor centre; and

$D$  is the diameter of the rotor.

As shown in Figure 4b, the reference distance  $R_0$  for vertical axis wind turbines is given by:

$$R_0 = H + D \quad (2)$$

where

$H$  is the vertical distance from the ground to the rotor equatorial plane; and

$D$  is the equatorial diameter.

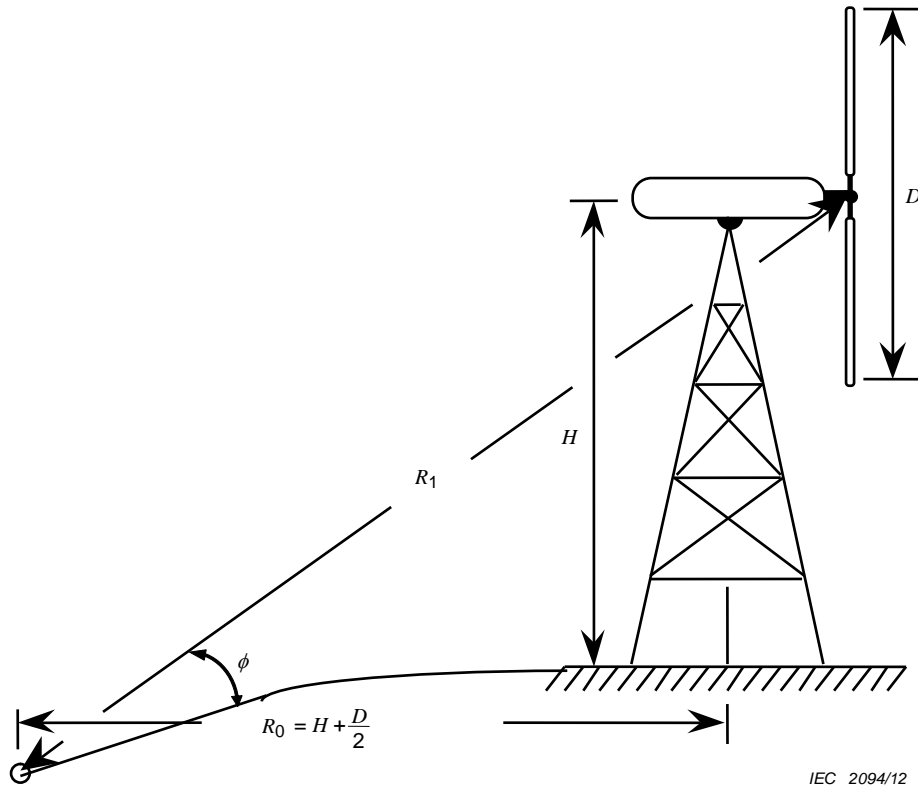

Figure 4a – Horizontal axis turbine

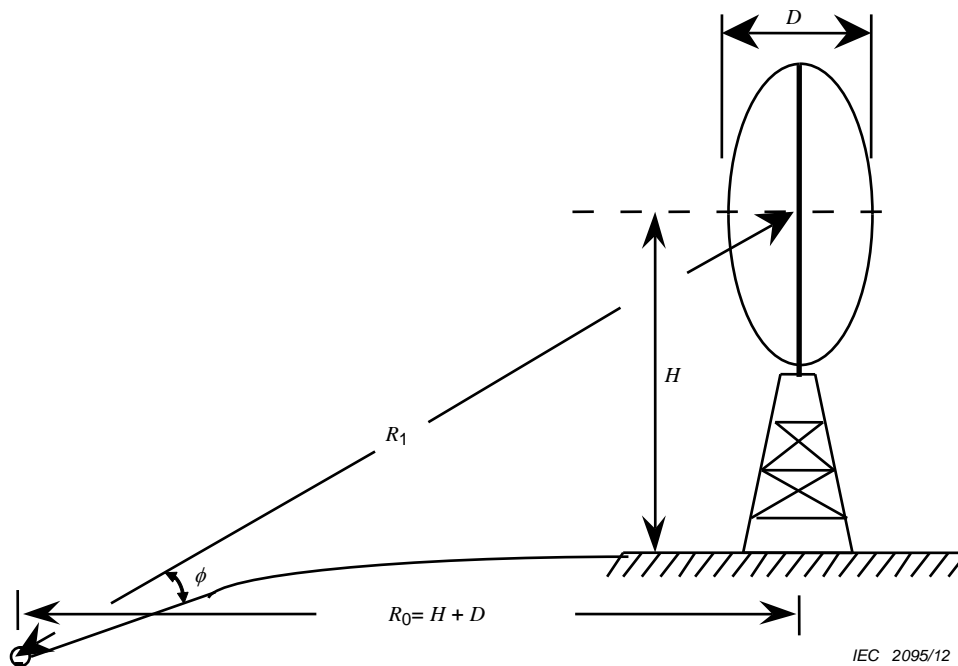

Figure 4b – Vertical axis turbine

Figure 4 – Illustration of the definitions of  $R_0$  and slant distance  $R_1$

To minimize influence due to the edges of the measurement board on the measurement results, it shall be ensured that the board is positioned flat on the ground. Any edges or gaps under the board should be levelled out by means of soil. The inclination angle  $\phi$ , as shown in Figure 4, shall be between 25° and 40°. This may require adjustment of the measurement position within the tolerances stated above. Additional considerations shall be made for measurements in complex terrain to avoid influence such as screening or reflections from obstructions or terrain.

The measurement position shall be chosen so that the calculated influence from any reflecting structures, such as buildings or walls, shall be less than 0,2 dB.

## 7.2 Acoustic measurements

### 7.2.1 General

The acoustic measurements shall permit the following information to be determined about the noise emission from the wind turbine at bin centre wind speeds:

- the A-weighted apparent sound power level;
- the A-weighted 1/3-octave band levels;
- the tonal audibility.

Optional measurements may include directivity, infrasound, low-frequency noise and impulsivity.

### 7.2.2 Acoustic measurement requirements

For all acoustic measurements, the following requirements are valid:

- The complete measurement chain shall be calibrated at least at one frequency before and after the measurements, or if the microphones are dis- and reconnected during the measurements.
- All acoustical signals shall be recorded and stored for later inspection.
- Periods with intruding intermittent background noise (as from aircraft) shall be omitted.
- The wind speed range is related to the specific wind turbine. As a minimum it is defined as the hub height wind speed from 0,8 to 1,3 times the wind speed at 85 % of maximum power rounded to wind speed bin centres.
- With the wind turbine stopped, and using the same measurement set-up, the background noise shall be measured immediately before or after each measurement series of wind turbine noise and during similar wind conditions. When measuring background noise, every effort shall be made to ensure that the background sound measurements are representative of the background noise that occurred during the wind turbine noise emission measurements. It is recommended to measure the background noise several times during the measurement period to cover the same wind speed range as for the total noise.
- The measurements shall cover as broad a range of wind speeds as practically possible. To obtain a sufficient range of wind speeds it may be necessary to take the measurements in several measurement series.
- At least 180 measurements shall be made overall for both total noise and background noise covering corresponding wind speed ranges.
- At least 10 measurements shall be made in each wind speed bin for both total noise and background noise.

Additionally, the following requirements are valid for the individual acoustic measurements.

### 7.2.3 A-weighted sound pressure level

The equivalent continuous A-weighted sound pressure level of the noise from the wind turbine shall be measured at the reference position. Each measurement shall be integrated over a period of 10 s.

### 7.2.4 A-weighted 1/3-octave band measurements

A-weighted 1/3-octave spectra are measured synchronously with the overall sound pressure levels as the energy average over 10 s periods. As a minimum, 1/3-octave bands with centre frequencies from 20 Hz to 10 kHz, inclusive, shall be measured. A-weighting shall be applied in the time domain i.e. before the frequency analysis.

Background measurements with the wind turbine stopped shall satisfy the same requirements.

### 7.2.5 A-weighted narrow band measurements

Narrowband spectra are measured synchronously with the sound pressure levels as the energy average over 10 s periods. Narrow band spectra shall be A-weighted. A Hanning window with an overlap of at least 50 % shall be used. The frequency resolution shall be between 1 and 2 Hz.

Additional noise measurements may be needed to determine the audibility of an identified tone as stated in 9.5.8.

Background noise measurements shall be used to determine that tones do not originate from background noise.

### 7.2.6 Optional acoustic measurements at positions 2, 3 and 4

Measurements in the non-reference positions shall fulfil the requirements for the reference position.

The measurements in the non-reference positions should be made simultaneously with corresponding measurements in the reference position. The measurements in the three non-reference positions can be made individually, but each one shall be made simultaneously with measurement in the reference position.

### 7.2.7 Other optional measurements

Additional measurements can be taken to quantify noise emissions that have definite character that is not described by the measurement procedures detailed in this standard.

Such character might be the emission of infrasound, low-frequency noise, modulation of broadband noise, impulses, or unusual sounds (such as a whine, hiss, screech or hum), distinct impulses in the noise (for example bangs, clatters, clicks, or thumps), or noise that is irregular enough in character to attract attention. These areas are discussed, and possible quantitative measures are outlined in Annex A. These measures are not universally accepted and are given for guidance only.

## 8 Non-acoustic measurements

### 8.1 General

The following non-acoustic measurements shall be made. Wind speed, electric power and rotational speed shall be sampled with at least 1 Hz. If other turbine parameters are measured the sampling rate shall be the same.



The wind speed  $V_{P,n}$  shall be obtained from measurements of the produced electric power using a documented power versus wind speed curve. The power curve shall represent the specific wind turbine type and preferably be measured according to IEC 61400-12-1 or IEC 61400-12-2. If a measured power curve is not available a calculated power curve may be used. If a calculated power curve is used an uncertainty in the range of a measured power curve can be assumed. The power curve shall give the relation between the wind speed at hub height and the electric power that the turbine produces for standard atmospheric conditions of 15 °C and 101,3 kPa.

The intervals on the power curve that can be used are all intervals where no duplicated values exist and the slope of the power curve including the uncertainty is positive.

The demand on the slope of the power curve is satisfied for any interval on the power curve, where the following is fulfilled:

$$(P_{k+1} - P_{tol}) - (P_k + P_{tol}) > 0 \quad (3)$$

where

- $k$  is the wind speed bin number of the power curve;
- $P_k$  is the power curve value at wind bin  $k$ ;
- $P_{tol}$  is the tolerance on the power reading, typical values for  $P_{tol}$  are 1 to 5 % of maximum value.

All power curve intervals meeting this demand are called *allowed range* of the power curve. For these intervals,

$$V_{H,n} = V_{P,n}$$

$V_{H,n}$  is the normalised hub height wind speed.

### 8.2.1.2 Determination of wind speed with nacelle anemometer

For all data points with power levels from the allowed range of the power curve, the average value of the ratio of the wind speed derived from the power curve  $V_{P,n}$  and the measured nacelle wind speed  $V_{nac,m}$ ,  $\kappa_{nac}$ , is derived. This value shall then be applied to the measured nacelle wind speed for the data points with power levels outside the allowed range of the power curve to derive the normalised wind speed using Equation (4).

$$V_{nac,n} = \kappa_{nac} V_{nac,m} \quad (4)$$

where

- $V_{nac,m}$  is the wind speed measured with the nacelle anemometer;
- $V_{nac,n}$  is the normalised wind speed from the nacelle anemometer, corrected to hub height.

If  $V_{nac,n}$  takes on values in the allowed range of the power curve, the data point shall be omitted from the analysis.

Outside the allowed range of the power curve  $V_{H,n} = V_{nac,n}$

## 8.2.2 Wind speed measurements during background noise measurements

For background noise measurements, the wind speed shall be measured with a met mast mounted anemometer at a height of at least 10 m. For in-situ calibration purposes the wind speed from the met mast shall be measured during the entire measurement.

For all data points with power levels from the allowed range of the power curve, the average value of ratio of the wind speed derived from the power curve  $V_{P,n}$  and the measured wind speed  $V_{Z,m, \kappa_Z}$  shall be derived. This ratio shall then be applied to the measured wind speed of the data points achieved during background noise measurements to derive the normalised wind speed using Equation (5).

$$V_{B,n} = \kappa_Z V_{Z,m} \quad (5)$$

where

$V_{Z,m}$  is the wind speed measured with an anemometer at height  $Z$  of at least 10 m;

$V_{B,n}$  is the normalised wind speed at hub height.

During background noise measurements  $V_{H,n} = V_{B,n}$

### 8.3 Downwind direction

The nacelle position with respect to the measurement board position will be observed to ensure that only data are used for the analysis, where the measurement board or microphone position is within  $\pm 15^\circ$  of the downwind direction derived from the nacelle position. It is recommended to measure the yaw position from the turbine controller simultaneously with the other turbine controller signals.

### 8.4 Other atmospheric conditions

Air temperature and pressure shall be measured and recorded at least every 2 h at a height of at least 1,5 m.

### 8.5 Rotor speed and pitch angle measurement

Measurement and reporting of rotor speed is mandatory and measurement and reporting of pitch angle is recommended. These data can be obtained from the wind turbine controller and shall be collected and arithmetically averaged synchronously with the acoustic measurements.

## 9 Data reduction procedures

### 9.1 General methodology for sound power levels and 1/3-octave band levels

The aim of this procedure is to produce sound power spectra in 1/3-octave bands and overall sound power levels using statistical methods. It should be noted there are two types of averaging used in the analysis: arithmetic averaging for non-acoustic data and energy averaging for acoustic data.

The uncertainty is also determined in this subclause and determined along with the sound power spectra in 1/3-octave bands and overall sound power levels. For most instruments the accuracy is given. Before using this in the text below, the accuracy shall be converted into an uncertainty. Guidelines are given in Annex C.

Noise and wind speed are measured and averaged over 10 s periods. Noise is measured both as the A-weighted sound pressure level  $L_{Aeq}$  and A-weighted 1/3-octave spectrum  $L_{Aeq,o}$ . Each 1/3-octave spectrum is normalized to the measured value for the  $L_{Aeq}$ .

The data points are sorted into wind speed bins and averaged giving:

- average wind speed;
- average A-weighted 1/3-octave spectrum;

- corresponding standard uncertainties.

The average wind speed may not be at the bin centre.

For each 1/3-octave band the value of the noise at the bin centre is found by linear interpolation between the adjacent bin average values. This results in a 1/3-octave spectrum at the centre of each bin.

The procedure described above applies to both the total noise and the background noise to determine bin centre spectra.

At each wind speed bin centre the wind turbine noise 1/3-octave spectrum is found by correcting the total noise spectrum with the background noise spectrum for the same wind speed bin centre. If the difference between the sum of the 1/3-octave bands of the total noise and the sum of the 1/3-octave bands of background noise is between 3 and 6 dB the result shall be marked with an asterisk when reported. If the difference is 3 dB or less, the result for that wind speed bin shall not be reported.

In the description below following subscripts and indexes are used:

- i* 1/3 octave band number (e.g. *i* = 1 for 20 Hz centre frequency, *i* = 2 for 25 Hz centre frequency, ... , *i* = 28 for 10 kHz centre frequency);
- j* 10 s measurement period number (each bin should have the minimum of 10 points per bin therefore *j* = 1 to 10 or greater);
- k* wind speed bin (i.e. *k* = 6 m/s bin, *k* = 6,5 m/s bin, *k* = 7 m/s bin, etc.);
- V* bin centre value;
- o* measured 1/3 octave spectrum;
- n* normalized spectrum;
- T* total noise;
- B* background noise;
- C* background corrected total noise.

The details of the procedure are described hereafter and illustrated in the flowchart in Figure 6.

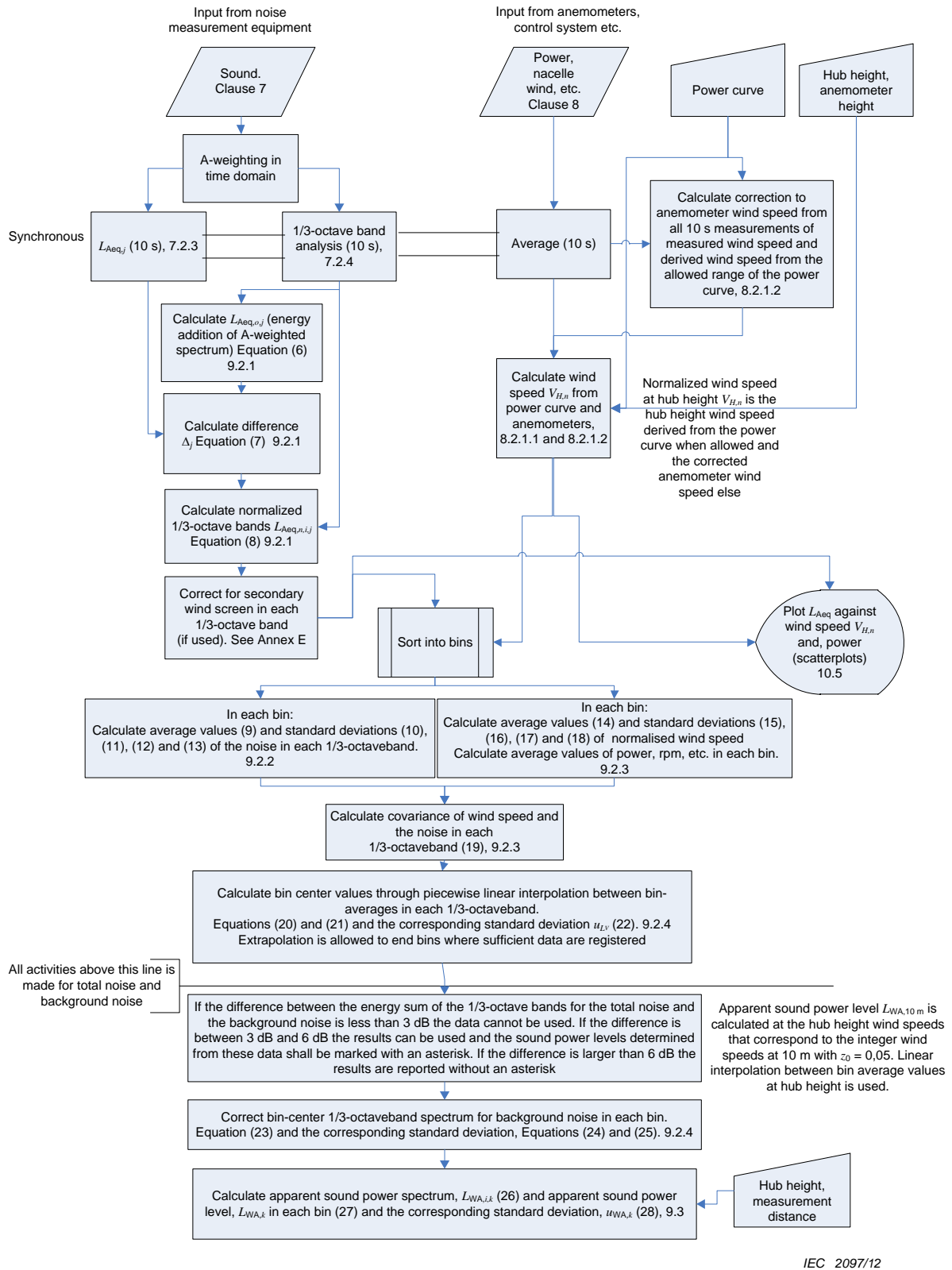

Figure 6 – Flowchart showing the data reduction procedure

## 9.2 Calculation of sound pressure levels

### 9.2.1 General

The noise is measured as an equivalent noise level  $L_{Aeq}$  and a 1/3-octave band spectrum with centre frequencies from 20 Hz to 10 kHz. The equivalent noise level  $L_{Aeq,o}$  is determined from the energy sum of the 1/3-octave bands. The difference  $L_{Aeq} - L_{Aeq,o}$  is determined.

$$L_{Aeq,o,j} = 10 \cdot \log \sum_{i=1}^{28} 10^{\left(\frac{L_{Aeq,i,j}}{10}\right)} \quad (6)$$

$$\Delta_j = L_{Aeq,j} - L_{Aeq,o,j} \quad (7)$$

This difference is added to each individual band in the 1/3-octave band spectrum to give the normalized 1/3-octave band spectrum for each measurement period  $j$ .

$$L_{Aeq,n,i,j} = L_{Aeq,i,j} + \Delta_j \quad (8)$$

where

$L_{Aeq,o,j}$  is the A-weighted sound pressure level calculated from the 1/3-octave spectrum in the measurement period  $j$ ;

$L_{Aeq,i,j}$  is the A-weighted sound pressure level at 1/3-octave band  $i$  in the measurement period  $j$ ;

$L_{Aeq,j}$  is the measured A-weighted sound pressure level in the measurement period  $j$ ;

$\Delta_j$  is the difference between the calculated A-weighted sound pressure level from the 1/3-octave spectrum and the measured A-weighted sound pressure level;

$L_{Aeq,n,i,j}$  is the normalized 1/3-octave band  $i$  in the measurement period  $j$ .

If a secondary wind screen is used, the normalized spectra shall be corrected for the influence of the secondary wind screen in 1/3-octave bands.

All the following analyses are made using the normalized 1/3-octave band spectra. The 1/3-octave band spectra are sorted into wind speed bins  $k$ . Average value and uncertainties for both sound pressure level and wind speed for each bin are calculated using the following expressions within each wind speed bin  $k$ .

The total noise and background noise are analysed using the same principles.

### 9.2.2 Calculation of average sound spectra and uncertainty per bin

The average sound pressure level  $\bar{L}_{i,k}$  for each 1/3-octave band  $i$  is calculated by Equation (9):

$$\bar{L}_{i,k} = 10 \cdot \log \left( \frac{1}{N} \sum_{j=1}^N 10^{\left(\frac{L_{i,j,k}}{10}\right)} \right) \quad (9)$$

where

$N$  is the number of measurements in wind speed bin  $k$ ;

$L_{i,j,k}$  is the sound pressure level of 1/3-octave band  $i$  of measurement period  $j$  in wind speed bin  $k$ .

The result will be one average 1/3-octave spectrum for each wind speed bin  $k$ .

The type A standard uncertainty on the average sound pressure level of 1/3-octave band  $i$  in wind speed bin  $k$   $s_{L_{i,k}}$  is calculated by Equation (10):

$$s_{L_{i,k}} = \sqrt{\left( \frac{\sum_{j=1}^N (L_{i,j,k} - \bar{L}_{i,k})^2}{N \cdot (N-1)} \right)} \quad (10)$$

where

$\bar{L}_{i,k}$  is the average sound pressure spectrum in wind speed bin  $k$  from Equation (9);

$L_{i,j,k}$  is the sound pressure level of 1/3-octaveband  $i$  of measurement period  $j$  in wind speed bin  $k$ .

The combined type B standard uncertainty on the energy averaged sound pressure level of 1/3-octave band  $i$ ,  $u_{L_{i,j}}$ , for each measurement period,  $j$ , is calculated by Equation (11).

Guidance for type B uncertainties are given in Annex C.

$$u_{L_{i,j}} = \sqrt{\sum_{q=1}^7 u_{L_{i,j,q}}^2} \quad (11)$$

where

$u_{L_{i,j,q}}$  is the type B standard uncertainty from source  $q$  on the average sound pressure level of 1/3-octave band  $i$  for each measurement period  $j$ .

The type B standard uncertainty on the average sound pressure level of 1/3-octave band  $i$  in wind speed bin  $k$ ,  $u_{L_{i,k}}$ , is calculated by Equation (12):

$$u_{L_{i,k}} = \sqrt{\left( \frac{1}{N} \sum_{j=1}^N u_{L_{i,j,k}}^2 \right)} \equiv u_{L_{i,j,k}} \quad (12)$$

where

$u_{L_{i,j,k}}$  is the combined type B standard uncertainty on the average sound pressure level of 1/3-octave band  $i$  for each measurement period  $j$ , see Equation (11). This value is the same for all values of  $j$ .

The combined standard uncertainty on the average sound pressure level of 1/3-octave band  $i$  in wind speed bin  $k$   $u_{\text{com},L_{i,k}}$  is calculated by Equation (13):

$$u_{\text{com},L_{i,k}} = \sqrt{s_{L_{i,k}}^2 + u_{L_{i,k}}^2} \quad (13)$$

### 9.2.3 Calculation of average wind speed and uncertainty per bin

The average wind speed,  $\bar{V}_k$ , in bin  $k$  is calculated by Equation (14):

$$\bar{V}_k = \frac{1}{N} \cdot \sum_{j=1}^N V_{j,k} \quad (14)$$

where

$N$  is the number of measurements in wind speed bin  $k$ ;

$V_{j,k}$  is the average value of wind speed at measurement period  $j$  in wind speed bin  $k$ .

The type A standard uncertainty on the average wind speed in bin  $k$   $s_{V,k}$ , is calculated by Equation (15):

$$s_{V,k} = \sqrt{\frac{\sum_{j=1}^N (V_{j,k} - \bar{V}_k)^2}{N \cdot (N - 1)}} \quad (15)$$

where

$V_{j,k}$  is the average wind speed for measurement period  $j$ ;

$\bar{V}_k$  is the average wind speed in wind speed bin  $k$ , see Equation (14).

The type B standard uncertainty on the wind speed for each measurement period  $j$   $u_{V_j}$  is calculated by Equation (16):

$$u_{V_j} = \sqrt{\sum_{q=8}^9 u_{V_j,q}^2} \quad (16)$$

where

$u_{V_j,q}$  is the type B standard uncertainty from source  $q$  on the average wind speed for each measurement period  $j$ .

The type B standard uncertainty on average wind speed in bin  $k$   $u_{V,k}$  is calculated by Equation (17):

$$u_{V,k} = \sqrt{\frac{1}{N} \cdot \sum_{j=1}^N u_{V_j}^2} \quad (17)$$

where

$u_{V_j}$  is the type B standard uncertainty on the average wind speed for each measurement period  $j$ , see Equation (16).

The combined standard uncertainty of the wind speed in bin  $k$ ,  $u_{\text{com},V,k}$ , is calculated by Equation (18):

$$u_{\text{com},V,k} = \sqrt{s_{\bar{V},k}^2 + u_{\bar{V},k}^2} \quad (18)$$

The corresponding covariance,  $\text{cov}_{LV,i,k}$ , is calculated by Equation (19):

$$\text{cov}_{LV,i,k} = \frac{1}{N-1} \cdot \sum_{j=1}^N (V_{j,k} - \bar{V}_k) \cdot (L_{i,j,k} - \bar{L}_{i,k}) \quad (19)$$

where

$V_{j,k}$  is the average wind speed measured in measurement period  $j$ ;

$\bar{V}_k$  is the average wind speed for bin  $k$ , see Equation (14);

$L_{i,j,k}$  is the measured noise level of 1/3-octave band  $i$  from measurement period  $j$  in wind speed bin  $k$ ;

$\bar{L}_{i,k}$  is the average noise level of the 1/3-octave band  $i$  in wind speed bin  $k$ , see Equation (9).

#### 9.2.4 Calculation of noise levels at bin centres including uncertainty

For both total noise and background noise, estimates for the sound pressure level of 1/3-octave band  $i$  at the bin centre wind speeds are calculated using linear interpolation between the bin average values. In principle the method is applicable for any wind speed.

The estimated sound pressure level at this wind speed  $V$  is calculated as

$$L_V(t) = (1-t) \cdot \bar{L}_k + t \cdot \bar{L}_{k+1} \quad (20)$$

where

$$\bar{V}_k \leq V < \bar{V}_{k+1}$$

The  $t$  value at a given wind speed  $V$  is calculated as

$$t = \frac{(V - \bar{V}_k)}{(\bar{V}_{k+1} - \bar{V}_k)} \quad (21)$$

The standard uncertainty on the calculated sound pressure levels at bin centre wind speed  $V$  is calculated using

$$u_{L_V}(t) = \sqrt{u_{L,t}^2(t) - \frac{\text{cov}_{LV,t}^2(t)}{u_{\bar{V},t}^2(t)}} \quad (22)$$

where

$$u_{L,t}^2(t) = (1-t)^2 \cdot u_{\text{com},L,k}^2 + t^2 \cdot u_{\text{com},L,k+1}^2$$

$$\text{cov}_{LV,t}(t) = (1-t)^2 \cdot \frac{\text{cov}_{LV,k}}{N_k} + t^2 \cdot \frac{\text{cov}_{LV,k+1}}{N_{k+1}}$$

$$u_V^2(t) = (1-t)^2 \cdot u_{\text{com},V,k}^2 + t^2 \cdot u_{\text{com},V,k+1}^2$$

$N_k$  is the number of measurements in wind speed bin  $k$ .

$N_k$  in Equation (22) is compensating for the use of standard uncertainty on average values for noise level and wind speed.

If the bin average of the wind speed is below the bin centre at the highest bin, extrapolation to the bin centre is allowed. If the bin average of the wind speed is above the bin centre at the lowest bin, extrapolation to the bin centre is allowed. Extrapolation is only allowed for bins with at least 10 measurement data points.

If the total noise level  $L_{V,T,i,k}$  is at least 3 dB higher than the background noise level,  $L_{V,B,i,k}$ , in the same 1/3-octave band  $i$ , the background corrected sound pressure level for 1/3-octave band  $i$  and the corresponding standard deviation on the value, are calculated using

$$L_{V,c,i,k} = 10 \cdot \log\left(10^{\left(\frac{L_{V,T,i,k}}{10}\right)} - 10^{\left(\frac{L_{V,B,i,k}}{10}\right)}\right) \quad (23)$$

$$u_{c,i,k} = \frac{\sqrt{\left(u_{L_{V,T,i}} \cdot 10^{\left(\frac{L_{V,T,i}}{10}\right)}\right)^2 + \left(u_{L_{V,B,i}} \cdot 10^{\left(\frac{L_{V,B,i}}{10}\right)}\right)^2}}{10^{\left(\frac{L_{V,T,i}}{10}\right)} - 10^{\left(\frac{L_{V,B,i}}{10}\right)}} \quad (24)$$

It is assumed the total and background noise are uncorrelated if the difference is larger than 3 dB. This may lead to an overestimation of the uncertainty if there is any correlation. For bins or 1/3-octave bands, where the total noise level,  $L_{V,T,i}$ , is less than 3 dB higher than the background noise level,  $L_{V,B,i}$ , a 3 dB correction is applied and the result marked with brackets [ ]. The uncertainty is calculated as if the difference is 3 dB, see Equation (25).

$$u_{c,i,k} = \frac{\sqrt{\left(u_{L_{V,T,i}} \cdot 10^{\left(\frac{L_{V,T,i}}{10}\right)}\right)^2 + \left(u_{L_{V,B,i}} \cdot 10^{\left(\frac{L_{V,T,i}-3}{10}\right)}\right)^2}}{10^{\left(\frac{L_{V,T,i}}{10}\right)} - 10^{\left(\frac{L_{V,T,i}-3}{10}\right)}} \quad (25)$$

### 9.3 Apparent sound power levels

Within each bin, the apparent sound power level for each 1/3-octave band  $L_{WA,i,k}$  is calculated from the corresponding background corrected sound pressure level for the same 1/3-octave band,  $L_{V,c,i,k}$ , at the bin centre wind speeds as follows:

$$L_{WA,i,k} = L_{V,c,i,k} - 6 + 10 \log \left[ \frac{4 \pi R_1^2}{S_0} \right] \quad (26)$$

where

- $L_{V,c,i,k}$  is the background corrected A-weighted sound pressure level in 1/3-octave band  $i$  at the bin centre wind speed  $k$  under meteorological reference conditions;
- $R_1$  is the slant distance in meters from the rotor centre to the microphone as shown in Figure 4; and
- $S_0$  is a reference area,  $S_0 = 1 \text{ m}^2$ .

The 6 dB constant in Equation (26) accounts for the approximate pressure doubling that occurs for the sound level measurements on a measurement board.

The estimate for the A-weighted sound power level in bin  $k$  is calculated by energy summing of all 1/3-octave band sound power values.

$$L_{WA,k} = 10 \cdot \log \sum_{i=1}^{28} 10^{\left( \frac{L_{WA,i,k}}{10} \right)} \quad (27)$$

If the difference between the sum of the 1/3-octave bands of the total noise and the sum of the 1/3-octave bands of the background noise is between 3 and 6 dB the result shall be marked with an asterisk when reported. If the difference is 3 dB or less, the result for that wind speed bin shall not be reported.

$$u_{L_{WA,k}} = \frac{\sum_{i=1}^{28} \left( u_{c,i,k} 10^{\left( \frac{L_{WA,i,k}}{10} \right)} \right)}{\sum_{i=1}^{28} 10^{\left( \frac{L_{WA,i,k}}{10} \right)}} \quad (28)$$

Equation (28) is valid for correlated uncertainties. The uncertainties of the sound power levels of the 1/3 octave bands are assumed to be correlated.

Guidance for Type B uncertainties are given in Annex C.

#### 9.4 Apparent sound power levels with reference to wind speed in 10 m height

To calculate the apparent sound power level with reference to wind speed in 10 m height,  $L_{WA,10 \text{ m},k}$ , at integer wind speeds within the measurement range, the following procedure is used:

Calculate the corresponding wind speed at hub height,  $V_{H,n}$  by using Equation (29). Then use linear interpolation and the background noise correction as described in Equations (20) to (26).

$$V_H = V_{10} \cdot \left( \frac{\ln\left( \frac{H}{z_{0 \text{ ref}}} \right)}{\ln\left( \frac{10}{z_{0 \text{ ref}}} \right)} \right) \quad (29)$$

$L_{WA,10 \text{ m},k}$  for integer wind speeds  $k$  within the measurement range with corresponding uncertainty,  $u_{L_{WA,10 \text{ m},k}}$  is calculated by using Equations (27) and (28).

## 9.5 Tonal audibility

### 9.5.1 General methodology for tonality

The presence of tones in the noise at different wind speeds shall be determined on the basis of the narrowband analysis. The procedure for tonality assessment is described by the flowchart in Figure 7.

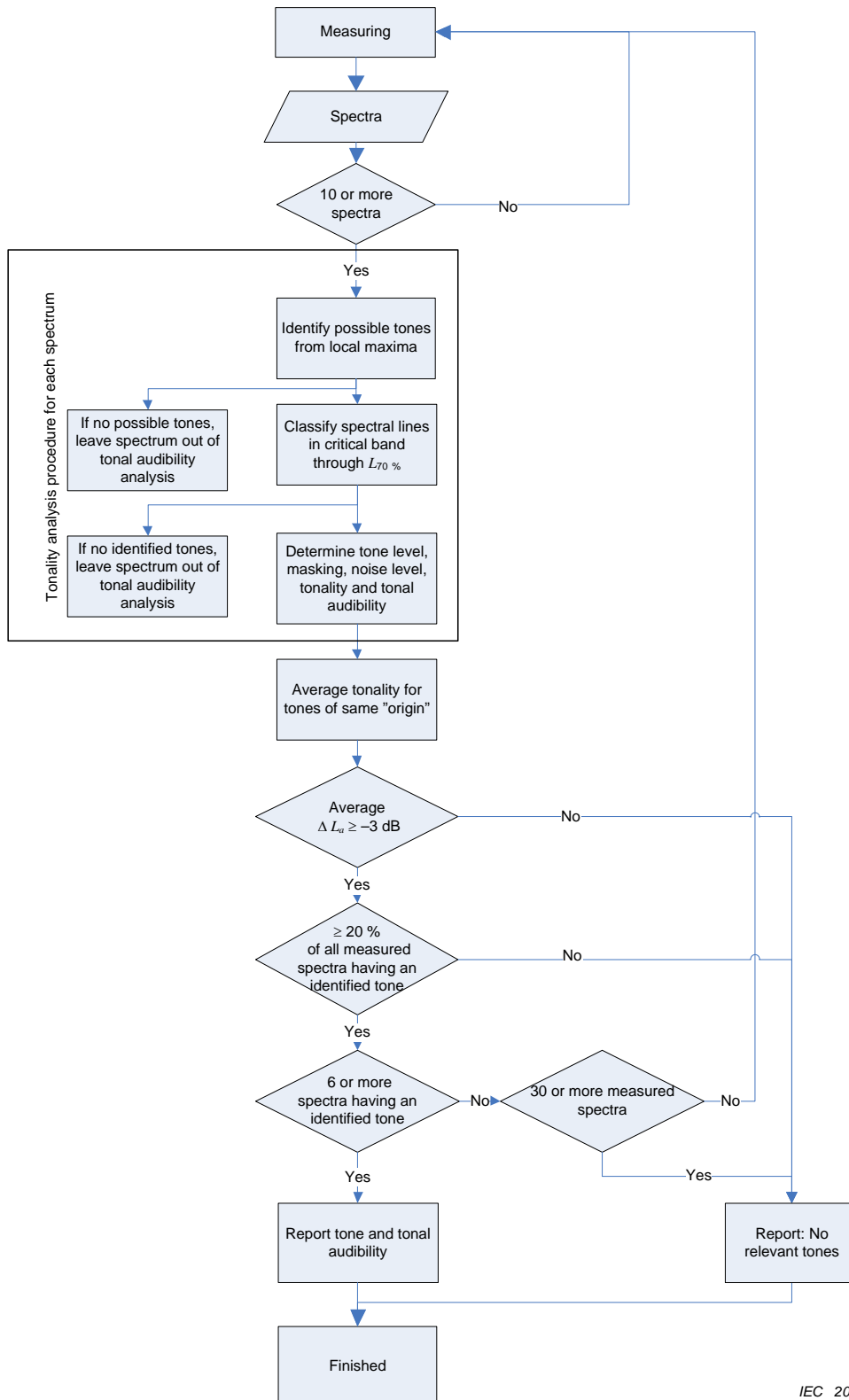

IEC 2098/12

Figure 7 – Flowchart for determining tonal audibility for each wind speed bin

The tonal analysis shall cover the same wind speed range as the sound power level measurement. The complete measurement shall be divided into 10 s energy averaged spectra as defined in 7.2.5.

All spectra are sorted into wind speed bins. The overall tonal audibility for a given wind speed bin can only be determined if at least 6 of the narrowband spectra for that wind speed bin have an identified tone with the same origin.

Tones of the same origin are defined as follows: Identified tones in different spectra are considered as tones of the same origin if they are within an interval  $\pm 25\%$  of the critical band centered at the frequency. Tones of the same origin are treated and reported as one tone.

For each spectrum with identified tone,  $j$ , in each wind speed bin

- The sound pressure level of the tone  $L_{pt,j,k}$  shall be determined.
- The sound pressure level of the masking noise  $L_{pn,j,k}$  in the critical band around the tone shall be determined.
- The tonality  $\Delta L_{tn,j,k}$ , the difference between the sound pressure level of the tone and the masking noise level, shall be found.
- The tonal audibility  $\Delta L_{a,j,k}$ , the difference between the tonality and the audibility criterion of the tone, shall be found.

The overall tonal audibility,  $\Delta L_{a,k}$ , is determined in each wind speed bin for each of the identified tones of the same origin as the energy average of the individual  $\Delta L_{a,j,k}$ . Only spectra with identified tones are included.

In exceptional cases (for example very broad tones consisting of many lines or masking noise with very steep gradients) this method may not give the correct results. In such cases, deviations from the prescribed method may be needed and shall be reported.

### 9.5.2 Identifying possible tones

A preliminary identification of tones is needed for the classification of the spectrum lines.

The following procedure is used to identify possible tones:

- a) find local maxima in the spectrum;
- b) calculate the critical band, a closed interval centred on the maxima with a bandwidth determined by:

$$\text{Critical bandwidth} = 25 + 75 \cdot \left( 1 + 1,4 \cdot \left[ \frac{f_c}{1000} \right]^2 \right)^{0,69} \quad (30)$$

where  $f_c$  is the frequency of the maxima in Hz;

- c) calculate the average energy in the critical band centred on each local maximum, not including the line of the local maximum and the two adjacent lines;
- d) if the local maximum is more than 6 dB above the average energy as calculated in the previous bullet, then it is a possible tone.

### 9.5.3 Classification of spectral lines within the critical band

The critical band shall be positioned with centre frequency coincident with the possible tone frequency. For possible tones with frequencies between 20 Hz and 70 Hz, the critical band is 20 Hz to 120 Hz.

If the centre frequency of a line is included in the critical band, the line is part of the critical band.

Within each critical band, every spectral line is classified as tone, masking, or neither, using the following procedure.

- a) Calculate the  $L_{70\%}$  sound pressure level, where  $L_{70\%}$  is the energy average of 70 % of spectral lines in the critical band with the lowest levels as shown in Figure 8.
- b) The criterion level is equal to  $L_{70\%}$  plus 6 dB as illustrated in Figure 9.
  - A line is classified as “masking” if its level is less than the criterion level.  $L_{pn,avg}$  is then the energy average of all the lines classified as masking as illustrated in Figure 10.
  - A line is classified as “tone” if its level exceeds  $L_{pn,avg}$  plus 6 dB.
  - Where there are several adjacent lines classified as “tone”, the line having the greatest level is identified. Adjacent lines are then only classified as “tone” if their levels are within 10 dB of the highest level.
  - A line is classified as “neither” if it cannot be classified as either “tone” or “masking”. Spectral lines identified as “neither” are ignored in further analysis. Figure 11 illustrates the classification of lines in a critical band.

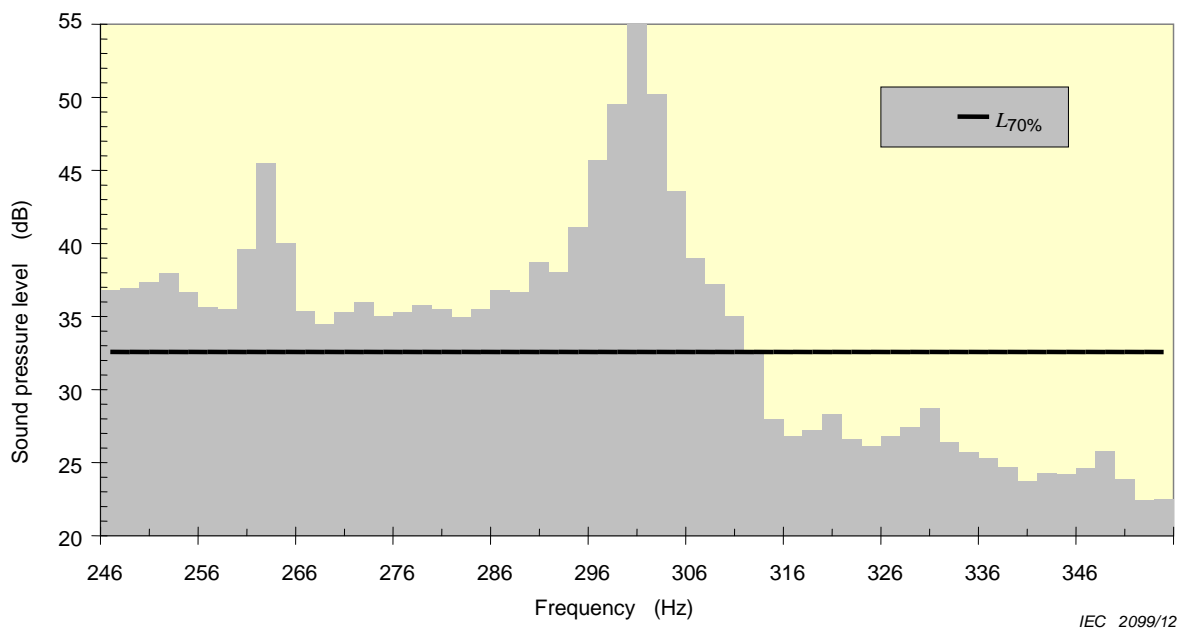

**Figure 8 – Illustration of  $L_{70\%}$  level in the critical band**

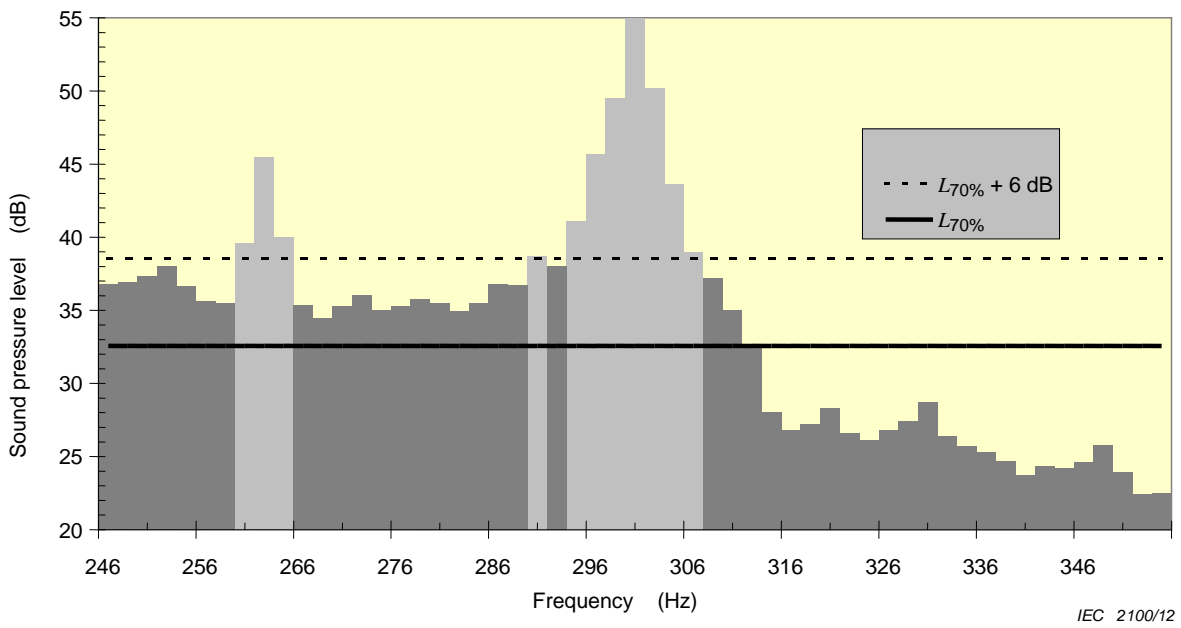

Figure 9 – Illustration of lines below the  $L_{70\%} + 6$  dB criterion

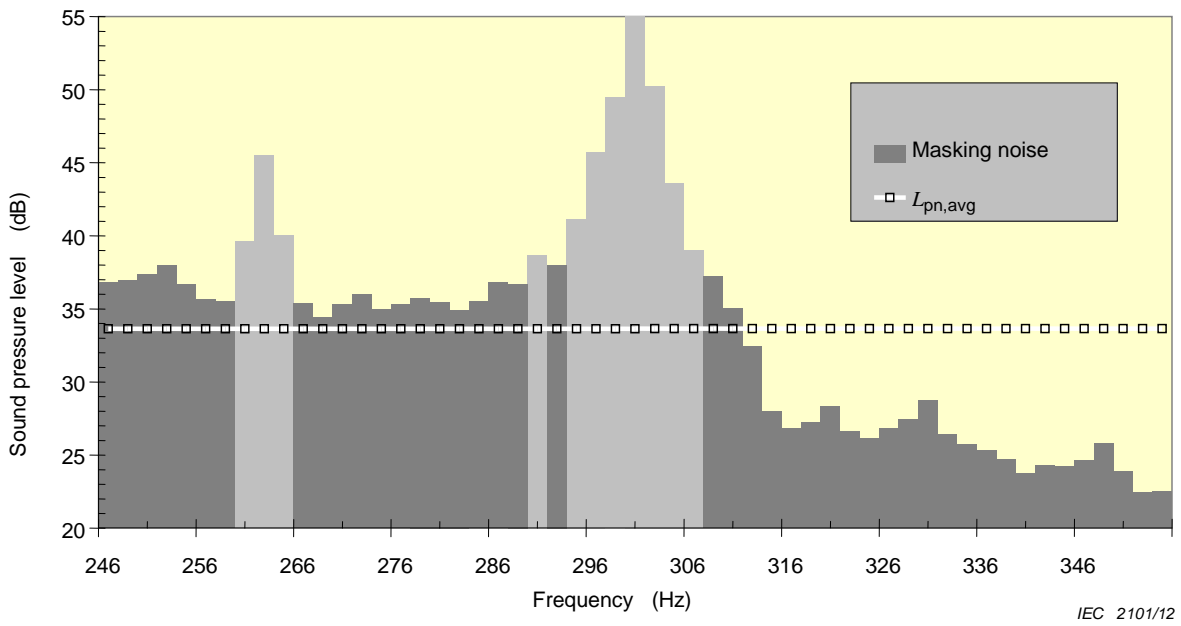

Figure 10 – Illustration of  $L_{pn,avg}$  level and lines classified as masking

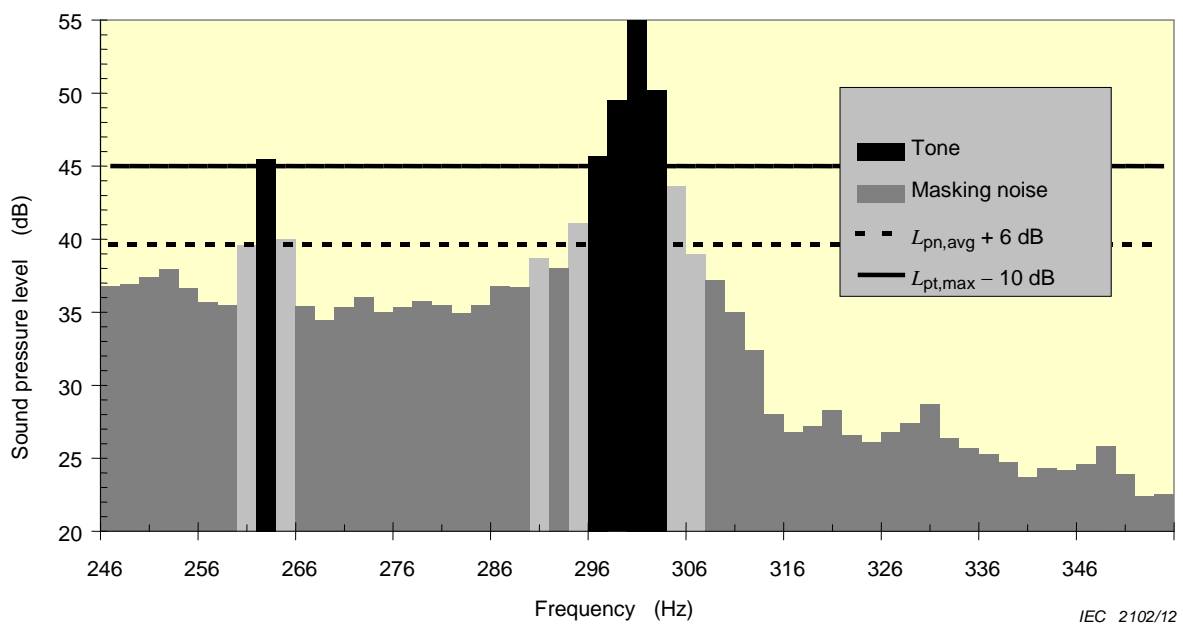

Figure 11 – Illustration of classifying all spectral lines

#### 9.5.4 Identified tone

An identified tone is a possible tone with one or more spectral lines classified as “tone”. According to 9.5.3, the spectral line with the highest level is the frequency of the tone.

#### 9.5.5 Determination of the tone level

The sound pressure level of the tone  $L_{pt,j,k}$  is determined by energy summing all spectral lines identified as tones within the critical band in 9.5.2. Where this involves 2 or more adjacent lines, a correction is applied for using the Hanning window. This requires dividing the energy sum by 1,5.

Note that if more than one tone is present within the same critical band, the above procedure is equivalent to energy summing the level of these individual tones.

#### 9.5.6 Determination of the masking noise level

The masking noise level,  $L_{pn,j,k}$ , is defined as follows:

$$L_{pn,j,k} = L_{pn,avg,j,k} + 10 \cdot \log \left[ \frac{\text{Critical bandwidth}}{\text{Effective noise bandwidth}} \right] \quad (31)$$

where  $L_{pn,avg,j,k}$  is the energy average of the spectral lines identified as “masking” within the critical band.

The effective noise bandwidth is 1,5 times the frequency resolution, which includes a correction for the use of the Hanning window.

#### 9.5.7 Determination of tonality

The tonality, the difference between the tone level and the level of the masking noise in the corresponding critical band, is given by Equation 32:

$$\Delta L_{tn,j,k} = L_{pt,j,k} - L_{pn,j,k} \quad (32)$$

### 9.5.8 Determination of audibility

For each value of  $\Delta L_{tn,j,k}$ , a frequency dependent correction shall be applied to compensate for the response of the human ear to tones of different frequency.

The “tonal audibility” for each spectrum,  $\Delta L_{a,j,k}$ , is defined as:

$$\Delta L_{a,j,k} = \Delta L_{tn,j,k} - L_a \quad (33)$$

$L_a$  is the frequency dependent audibility criterion, defined as:

$$L_a = -2 - \log \cdot \left[ 1 + \left( \frac{f}{502} \right)^{2,5} \right] \quad (34)$$

where  $f$  is the frequency of the tone maximum in the critical band, in Hz.

Note that this criterion curve has been determined from listening tests, and reflects the subjective response of a “typical” listener to time-invariant tones of different frequencies.

The  $\Delta L_{a,j,k}$  are energy averaged to one  $\Delta L_{a,k}$  for each tone of the same origin in each bin.

For tonal audibilities meeting the condition:

$$\Delta L_{a,k} \geq -3,0 \text{ dB} \quad (35)$$

The tonal audibility is reported. Except if:

- $\Delta L_{a,k} \geq -3,0$  dB and less than 20 % of 10 spectra or more, contain identified tones with the same origin the values of  $\Delta L_{a,k}$  shall be reported as “No relevant tones.”
- $\Delta L_{a,k} \geq -3,0$  dB and more than 20 % but less than 6 spectra contain identified tones with the same origin more measurements are needed. Up to 30 spectra may be necessary.

For tonal audibilities where:

$$\Delta L_{a,k} < -3,0 \text{ dB} \quad (36)$$

the values of  $\Delta L_{a,k}$  shall be reported as “No relevant tones”.

A tone is audible if the tonal audibility is above 0 dB.

### 9.5.9 Background noise

Narrowband spectra shall be made of the background noise for each wind speed bin. If tones originating from the background significantly affect the audibility analysis then measures shall be taken to establish the degree to which this occurs and these measures shall be reported.

No correction for broadband background noise is made.

## 10 Information to be reported

### 10.1 General

The configuration of the wind turbine and its operating conditions shall be reported as follows.

### 10.2 Characterisation of the wind turbine

The wind turbine configuration shall include the following information:

- Wind turbine details:
  - manufacturer;
  - model number;
  - serial number.
- Operating details:
  - vertical or horizontal axis wind turbine;
  - upwind or downwind rotor;
  - hub height;
  - horizontal distance from rotor centre to tower axis;
  - diameter of rotor;
  - tower type (lattice or tube);
  - passive stall, active stall, or pitch controlled turbine;
  - constant or variable speed;
  - power curve;
  - rotational speed at wind bins;
  - rated power output;
  - control software version.
- Rotor details:
  - rotor control devices;
  - presence of vortex generators, stall strips, serrated trailing edges;
  - blade type;
  - serial number;
  - number of blades.
- Gearbox details:
  - manufacturer;
  - model number;
  - serial number.
- Generator details:
  - manufacturer;
  - model number;
  - serial number.

### 10.3 Physical environment

The following information on the physical environment at and near the site of the wind turbine and the measuring positions shall be reported:

- details of the site including location, site map and other relevant information;
- type of topography/terrain (hilly, flat, cliffs, mountains, etc.) in surrounding area (nearest 1 km);
- surface characteristics (such as grass, sand, trees, bushes, water surfaces);
- nearby reflecting structures such as buildings or other structures, cliffs, trees, water surfaces;
- other nearby sound sources possibly affecting background noise level, such as other wind turbines, highways, industrial complexes, airports;
- two photos, one taken in the direction of the turbine from the reference microphone position, and one taken from the wind mast toward the turbine;
- a photo of the microphone on the measurement board positioned on the ground and immediate surroundings, see Figure 2.

#### 10.4 Instrumentation

The following information on the measurement instrumentation shall be reported:

- manufacturer(s);
- instrument name and type;
- serial number(s);
- other relevant information (such as last calibration date);
- met mast anemometer position and height for each measurement series;
- influence of secondary wind screen, if used;
- measurement position of each microphone for each measurement series.

#### 10.5 Acoustic data

The following acoustic data shall be reported:

- measurement position of each microphone for each measurement series;
- time and date of each measurement series;
- apparent sound power level  $L_{WA,k}$  at bin centre wind speeds at hub height;
- apparent sound power level  $L_{WA,10\text{ m},k}$  at integer wind speeds at 10 m height;
- a plot showing all measured data pairs at reference position 1 of the measured total noise and background noise (with different symbols). Differentiate in the plot if the wind speed was derived from different methods. On the plot, the axes of  $L_{Aeq}$  and  $V_{H,n}$  shall be linear, and scaled so that 1 m/s corresponds to 2 dB;
- a plot showing all measured total noise versus electrical power data;
- table and plot of sound power spectrum in 1/3-octaves for each bin centre wind speed; coordinates plotted at 1 octave = 10 dB, and levels bracketed as appropriate;
- table showing total noise and background noise. The values shall be calculated as the energy sum of the average 1/3-octave band spectra for each bin. The corrected  $L_{Aeq}$  at bin centre values calculated from the corrected 1/3-octave band spectrum at the bin centre can be included in the table. If the difference between total noise and background noise is between 3 and 6 dB the result shall be marked with an asterisk. If the difference is 3 dB or less the result shall not be used.

For each bin centre wind speed  $k$ :

- $\Delta L_{tn,j,k}$  for each identified tone;
- $\Delta L_k$  for each identified tone;

- $\Delta L_{a,k}$  for each identified tone;
- frequency for each identified tone;
- narrowband spectra of total and background noise as an overlay plot per bin.

Optional acoustic data that may be reported includes:

- low frequency noise;
- infrasound;
- impulsivity;
- amplitude modulation;
- other noise characteristics, if any.

### 10.6 Non-acoustic data

The following non-acoustic data shall be reported:

- wind speed determination method(s);
- plots of wind speed from the power curve relative to measured nacelle wind speed and met mast measured wind speed;
- rotor rotational speed;
- air temperature;
- atmospheric pressure;
- roughness length (estimated);
- range of the downwind direction during the measurement including the method used to ensure the yaw direction was within  $\pm 15^\circ$  of the microphone position.

Optional non-acoustic data that may be reported include:

- estimates or measurements of the turbulence intensity during acoustic measurements;
- whether the turbulence intensity data were determined by measurement or by inference from meteorological conditions.

### 10.7 Uncertainty

The uncertainty of the following reported acoustic quantities shall be assessed and reported:

- description of type B uncertainties;
- apparent sound power levels at bin centre wind speeds;
- 1/3-octave band spectrum of the noise at the reference position at bin centre wind speeds.

Guidance for the assessment of measurement uncertainty can be found in Annex C and in ISO/IEC Guide 98-3, *Uncertainty of measurement – Part 3: Guide to the expression of uncertainty in measurement (GUM:1995)*.

## Annex A (informative)

### Other possible characteristics of wind turbine noise emission and their quantification

#### A.1 General

In addition to those characteristics of wind turbine noise described in the main text of this standard, the noise emission may also possess some, or all, of the following:

- infrasound;
- low-frequency noise;
- impulsivity;
- low-frequency modulation of broad band or tonal noise;
- other, such as a whine, hiss, screech or hum, etc., distinct impulses in the noise, such as bangs, clatters, clicks, or thumps, etc.

These characteristics are described briefly below, and possible quantitative measures discussed.

It should be noted that certain aspects of infrasound, low frequency noise, impulsivity and amplitude modulation are not fully understood at present. Thus it may prove that measurement positions farther away from the wind turbine than those specified in the standard may be preferable for the determination of these characteristics.

#### A.2 Infrasound

Sound at frequencies below 20 Hz is called infrasound. Although such sound is barely audible to the human ear, it can still cause problems such as vibration in buildings and, in extreme cases, can cause annoyance. If infrasound is thought to be emitted, an appropriate measure is the G-weighted sound pressure level according to ISO 7196. Research has shown that modern upwind wind turbines do not produce audible infrasound.

#### A.3 Low frequency noise

The general procedure extends one-third octave bands to 20 Hz and covers the relevant frequency range to describe the low frequency noise. From the data it is possible to predict the low frequency noise levels in the far field.

A disturbance can be caused by low-frequency noise with frequencies in the range from 20 Hz to 100 Hz. The annoyance caused by noise dominated by low frequencies begins when the noise is clearly audible. At levels close to the hearing threshold the nuisance of such a noise may be overestimated if assessed using only  $L_{Aeq}$  values.

#### A.4 Impulsivity

An impulsive, thumping sound may be emitted from a wind turbine due, for example, to the interaction of the blade with the disturbed wind around the tower. Impulsivity is a measure of the degree of this thumping.

A quantification of impulsivity can be obtained from the average of several measurements of the difference between the C-weighted “impulse hold” and maximum C-weighted “slow” sound pressure levels.

### **A.5 Amplitude modulation of the broad band noise**

In some cases, it is possible that the broadband noise emitted by a wind turbine is modulated by the blade passage frequency giving rise to a characteristic “swishing” or “whooshing” sound.

This modulation can be displayed by recording the measured A-weighted sound pressure level with time weighting  $F$  for at least ten full rotations of the rotor.

The characteristics of this modulation can be influenced by local atmospheric conditions (see Annex B), and for this reason such conditions should be recorded during measurements.

### **A.6 Other noise characteristics**

If the noise emission contains a whine, hiss, screech, hum, bang, clatter, click, thump, etc., then this characteristic should be reported. A full description as possible of the noise should be given in words, and any measurements that illustrate the nature of the noise should be taken.

## **Annex B** (informative)

### **Assessment of turbulence intensity**

Turbulence is a natural part of the wind environment, and as it passes through the rotor disk, it causes unsteady pressures on the blades that radiate noise. Studies suggest that at high power levels or wind speeds, noise due to inflow turbulence can become the dominant source of aerodynamic noise emission from a wind turbine.

Because of its effect on overall noise emission, turbulence levels should be assessed and recorded during acoustic measurements. The preferred method is by direct measurement of wind speed within at least three time periods of 10 min each, and at a sampling rate of at least 1 Hz. Both the average and standard deviation of the wind speed are determined from the measured data for each 10 min period. The average turbulence intensity is then determined as the average of the ratio of standard deviation divided by the average wind speed for each period.

Turbulence intensity is usually measured with an anemometer at rotor centre height in undisturbed flow. Using a 10 m met mast, power curve, or nacelle anemometer gives an estimated value. These can be used for relative measurements on the same turbine, in order to compare noise measurement results.

If such turbulence measurements are not practical, turbulence levels may be inferred from knowledge of the local atmospheric stability and surface roughness. On clear, sunny days the ground heats up and turbulent energy arises in the atmospheric boundary layer due to air buoyancy effects. This represents an unstable atmospheric boundary layer and results in high turbulence levels. On the other hand, after sunset the ground often cools, due to radiant loss to the night sky, and cold air settles below warmer air. This condition represents stable atmospheric conditions, wherein turbulent mixing in the boundary layer is inhibited, and turbulence levels are low. The surface roughness of the measurement site also affects the levels of turbulence. High turbulence levels can occur over rougher ground surfaces and over complex terrain. The time of day, cloud cover during measurements, and the surface roughness, should be reported as an alternative to reporting measured turbulence levels.

## Annex C (informative)

### Assessment of measurement uncertainty

#### C.1 General

This Annex gives some guidance on how to make uncertainty determinations.

#### C.2 Uncertainty components of type A and B

The measurement uncertainty of each of the reported acoustic quantities should be derived and reported as the combined standard uncertainty in the manner defined in this annex. Additional guidance on applying the methods is contained in the ISO/IEC Guide 98-3, *Uncertainty of measurement – Part 3: Guide to the expression of uncertainty in measurement (GUM:1995)*. In this annex, distinction is made between type A uncertainty components that are evaluated by using statistical methods to a series of repeated determinations, and type B uncertainty components that are evaluated by judgement, using different kinds of relevant information including experience from similar situations. Uncertainty components of both type A and B are expressed in the form of standard uncertainties and are combined by the method of combination of variances to form the combined standard uncertainty.

#### C.3 Site effects

When the uncertainty of the measurement results are evaluated, it is important to take into account the influence that the actual measurement site can have upon the measured wind speed and upon the acoustic conditions of the microphone mounting board. If the site terrain is non-uniform, the measured wind speed can deviate from the wind speed incident on the rotor. The deviation will increase with increasing distance between the rotor centre and the anemometer. If the ground is sloping or uneven, the conditions for the microphone mounting board may not be fully met, and the measured sound pressure levels may be inaccurate. The uncertainty of spectra will be larger than for A-weighted total levels and will increase with decreasing board size. The site effects are type B uncertainty components.

#### C.4 Uncertainty on acoustic parameters

##### C.4.1 Apparent sound power spectra and levels

This subclause describes the uncertainty components that, based on current knowledge, are the most important with respect to the apparent sound power spectra and levels.

The parameter describing the type A uncertainty is the standard error of the estimated noise spectra at each wind speed bin centre for each 1/3-octave band in the spectrum. Details on this are found in Clause 9.

The following are considered uncertainty components of type B for sound level determination:

- calibration of the acoustic instruments,  $u_{B1}$ ;
- tolerances on the chain of acoustic measurement instruments,  $u_{B2}$ ;
- uncertainty on the acoustic conditions for microphone mounting board,  $u_{B3}$ ;
- uncertainty on the wind screen insertion loss,  $u_{B4}$ ;
- uncertainty on the distance from microphone to hub and direction,  $u_{B5}$ ;

- uncertainty on the acoustic impedance of air, air absorption,  $u_{B6}$ ;
- uncertainty on the acoustic emission of wind turbine due to changing weather conditions, including turbulence,  $u_{B7}$ .

The following are considered uncertainty components of type B for wind speed determination.

- uncertainty on the measured wind speed, including anemometer calibration and site effects, or on derived wind speed, including power reading uncertainty,  $u_{B8}$ ;
- uncertainty on the measured and derived wind speed from the power curve uncertainty,  $u_{B9}$ .

For all of the type B uncertainties mentioned here, a rectangular distribution of possible values is assumed for simplicity with a range described as “ $\pm a$ ”. The standard uncertainty for such a distribution is:

$$u = \frac{a}{\sqrt{3}} \tag{C.2}$$

Table C.1 and Table C.2 present the possible values of the uncertainty components, which are given as examples. They should only be used as guidance for evaluations to be made in actual cases.

**Table C.1 – Examples of possible values of type B uncertainty components relevant for apparent sound power spectra**

Component	Possible typical range dB	Possible typical standard uncertainties dB
Calibration, $u_{B1}$	$\pm 0,3$	0,2
Instrument, $u_{B2}$	Frequency dependent, can be taken from calibration certificate	
Board, $u_{B3}$	$\pm 0,5$	0,3
Wind screen insertion loss, $u_{B4}$	See annex E	
Distance and direction, $u_{B5}$	$\pm 0,2$	0,1
Air absorption, $u_{B6}$	See annex G	
Weather conditions, $u_{B7}$	$\pm 0,8$	0,5

**Table C.2 – Examples of possible values of type B uncertainty components for wind speed determination relevant for apparent sound power spectra**

Component	Possible typical range m/s	Possible typical standard uncertainties m/s
Wind speed, measured <sup>a</sup> , $u_{B8}$	$\pm 1,2$	0,7
Wind speed, derived <sup>b</sup> , $u_{B8}$	$\pm 0,3$	0,2
Wind speed, power curve, $u_{B9}$	$\pm 0,3$	0,2
<sup>a</sup> Through nacelle anemometer or met mast.		
<sup>b</sup> Through power curve.		

The combined standard uncertainty is found as given in Clause 9.

## Annex D (informative)

### Apparent roughness length

#### D.1 General

Roughness length is the parameter used for calculation of the wind speed at different heights based only on the terrain conditions. In Table D.1 guidance on how to estimate the roughness length is given. Since this is crude estimate, valid only for cloudy conditions, this annex gives some guidance on how to determine an apparent roughness length either from wind speed measurements or from typical wind shear data measured during site evaluation.

**Table D.1 – Roughness length**

Type of terrain	Roughness length $z_0$ m
Water, snow or sand surfaces	0,000 1
Open, flat land, mown grass, bare soil	0,01
Farmland with some vegetation	0,05
Suburbs, towns, forests, many trees and bushes	0,3

#### D.2 Method for determination of roughness length.

Roughness length is a parameter in the equation for the logarithmic wind profile. The equation for the logarithmic wind profile is given in Equation (D.1).

$$V_z = V_{z,\text{ref}} \cdot \frac{\left( \ln\left(\frac{z}{z_0}\right) \right)}{\left( \ln\left(\frac{z_{\text{ref}}}{z_0}\right) \right)} \quad (\text{D.1})$$

where,

- $V_z$  is the wind speed at height  $z$  above ground level;
- $V_{z,\text{ref}}$  is the wind speed at height  $z_{\text{ref}}$  above ground level (typical hub height);
- $z$  is the height above ground for the desired wind speed;
- $z_{\text{ref}}$  is the height above ground where the wind speed is known;
- $z_0$  is the roughness length in the wind direction under consideration.

Equation (D.1) can be rearranged to

$$z_0 = e^{\left( \frac{V_z \cdot \ln(z_{\text{ref}}) - V_{z,\text{ref}} \cdot \ln(z)}{V_z - V_{z,\text{ref}}} \right)} \quad (\text{D.2})$$

By measuring the wind velocity in two different heights above ground we are able to determine the roughness length in the wind direction under consideration. The roughness length is determined by averaging all the calculated 10 s roughness length during the

complete noise measurement. Preferable  $z_{ref}$  is chosen to be hub height, and  $z$  is chosen to be tip low height, in order to minimise local ground effects.

### D.3 Conversion of wind shear to apparent roughness length

Very often wind shear is measured during site evaluation. Wind shear is another measure for the variation of wind speed with height as seen in (D.3). The wind shear can be converted to an apparent roughness length by equalling Equations (D.1) and (D.3).

$$V_z = V_{z,ref} \cdot \left( \frac{z}{z_{ref}} \right)^\alpha \quad (D.3)$$

where,

- $V_z$  is the wind speed at height  $z$  above ground level;
- $V_{z,ref}$  is the wind speed at height  $z_{ref}$  above ground level (typical hub height);
- $z$  is the height above ground for the desired wind speed;
- $z_{ref}$  is the height above ground where the wind speed is known;
- $\alpha$  is the wind shear factor for the wind direction under consideration.

By solving for  $z_0$  we get the following result:

$$z_0 = e^{\left( \frac{z^\alpha \cdot \ln(z_{ref}) - z_{ref}^\alpha \cdot \ln(z)}{z^\alpha - z_{ref}^\alpha} \right)} \quad (D.4)$$

By calculating  $z_0$  this way, we can find two intersection point using the two different wind profiles, namely for a height equal to  $z$  and a height equal to  $z_{ref}$ , therefore we chose the equality to be valid for 10 m height and hub height, and thereby we can rewrite the equation to the equation for determination of the apparent roughness length from wind shear.

$$z_0 = e^{\left( \frac{10^\alpha \cdot \ln(H) - H^\alpha \cdot \ln(10)}{10^\alpha - H^\alpha} \right)} \quad (D.5)$$

where,

- $H$  is the hub height of the turbine;
- $\alpha$  is the wind shear factor for the measured wind direction.

The measured roughness length (see Equation (D.2), the apparent roughness length (see Equation (D.5)) or the roughness length found from Table D.1 shall be used, when finding the sound power level as a function of wind speed at 10 m height.

## **Annex E** (informative)

### **Characterization of a secondary wind screen**

#### **E.1 General**

A secondary wind screen can be used when measurements are made at high wind speeds and at low frequencies. The secondary wind screen improves the signal to noise ratio at the lowest and highest frequencies by reducing wind induced noise in the microphone.

If the secondary windscreen is used, the influence of the secondary windscreen on the frequency response shall be documented and corrected for in the results. The insertion loss of the wind screen should cover the meteorological conditions for which it is intended, i.e. different degrees of humidity, moisture.

#### **E.2 Secondary wind screen**

The secondary wind screen can be designed in different ways. For example, it could consist of a wire frame of approximate hemispherical shape which is covered with a 13 mm to 25 mm layer of open cell foam with a porosity of 4 to 8 pores per 10 mm or different types of textile. The secondary hemispherical windscreen shall be placed symmetrically over the smaller primary windscreen.

The diameter of the wind screen shall be at least 450 mm.

#### **E.3 Insertion loss**

As the secondary wind screen is part of the entire measurement chain the insertion loss of the secondary wind screen shall be measured with high precision. The following measurement procedure shall be followed.

#### **E.4 Measurement procedure**

The measurement setup is similar to the measurement situation for wind turbine noise measurements.

The insertion loss is measured using a loudspeaker and a pink noise signal.

The test microphone is put on a measurement board at a horizontal distance of 6 m from the loudspeaker. The loudspeaker is put on a stand at a height of 4 m. The horizontal distance of the measurement board is varied by  $\pm 20\%$ , corresponding to the allowed variation in measurement distance.

An extra microphone, a control microphone, is put on a separate measurement board next to the first measurement board. The purpose of this is to monitor the noise from the loudspeaker during the measurements, looking for variation in the noise emission. A half standard wind screen is applied on each of the two microphones.

The secondary wind screen is applied to the test microphone. Noise is emitted from a loudspeaker and the resulting sound pressure levels at the microphone positions are recorded for 1 min to 2 min. The secondary wind screen is removed from the test microphone and another recording is made. This is repeated 3 times. The background noise is measured

before and after these measurements. This procedure is repeated with 3 different distances of the measurement board: 4,8 m, 6,0 m, and 7,2 m. All measurements are made in 1/3-octave bands.

The insertion loss can then be determined as the level difference with and without the secondary wind screen as an arithmetic average for the 9 measurements. The standard deviation shall be calculated as well. As the result is a small difference between high sound pressure levels it is necessary to normalize the level difference with the level difference between the corresponding measurements from the control microphone.

The background noise in each 1/3-octave band shall be at least 3 dB below the noise with the loudspeaker on. For 1/3-octave bands where this is not the case the insertion loss cannot be reported.

At frequencies below 100 Hz the insertion loss can be assumed equal to the insertion loss at 125 Hz if background noise has prevented measurements.

### E.5 Other demands

The values of the insertion loss shall be within  $-1,0$  dB to  $3,0$  dB for any one-third octave band.

The difference in insertion loss between 2 neighbouring 1/3-octave bands shall not exceed 2 dB to prevent a distortion of the FFT-spectra, where it is not possible to correct for the secondary wind screen.

### E.6 Examples of secondary wind screens

Two examples of secondary wind screens are shown in Figure E.1 and Figure E.2.



IEC 2103/12

Figure E.1 – Example 1 of a secondary wind screen



IEC 2104/12

**Figure E.2 – Example 2 of secondary wind screen**

### Examples of insertion loss

In Table E.1 and Figure E.3 the insertion loss of a secondary wind screen is reported. The insertion loss should be measured down to at least 100 Hz. Below 100 Hz the insertion loss can be equalled to 0 for most secondary wind screens.

**Table E.1 – Example on reporting of insertion loss**

Frequency 1/3-octave band, Hz	Insertion loss dB	Standard deviation dB
20	0,1	0,2
25	0,2	0,4
31,5	0,1	0,2
40	0,1	0,2
50	0,1	0,3
63	0,0	0,3
80	0,2	0,2
100	0,2	0,1
125	0,1	0,1
160	-0,1	0,2
200	-0,3	0,3
250	0,0	0,2
315	0,3	0,2
400	0,6	0,2
500	1,2	0,2
630	1,7	0,2
800	1,7	0,4
1 000	0,7	0,3
1 250	1,3	0,7
1 600	1,7	0,5
2 000	1,6	0,5
2 500	2,3	0,4
3 150	2,6	0,6
4 000	2,1	0,9
5 000	0,8	1,3
6 300	-0,1	0,7
8 000	0,7	1,0
10 000	1,6	1,9

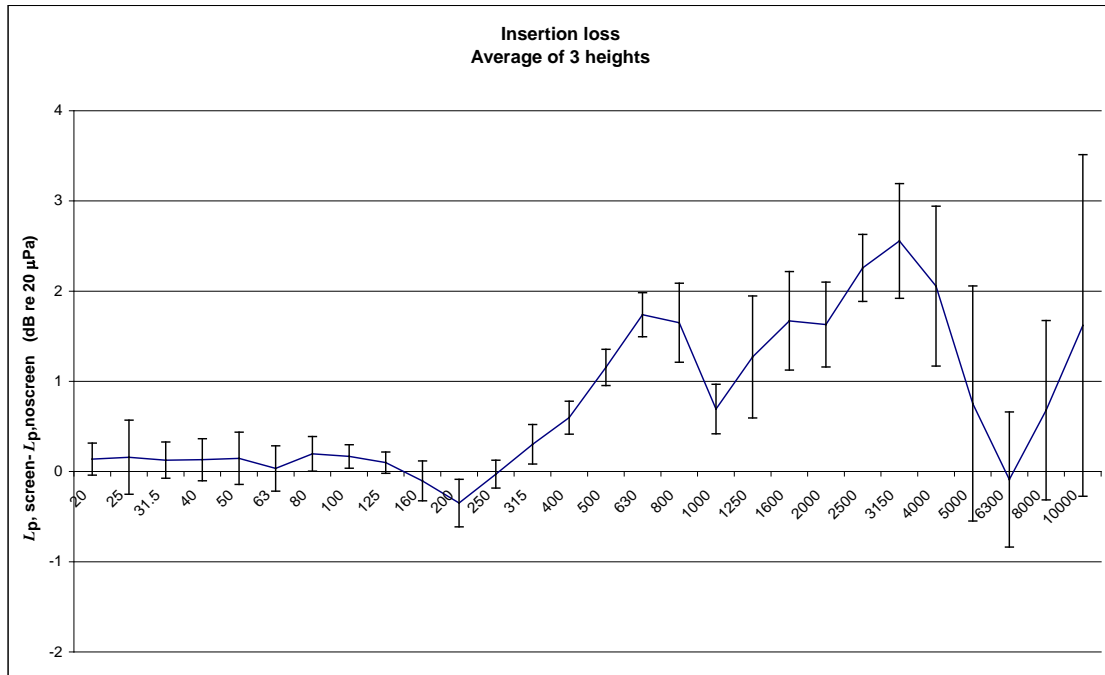

IEC 2105/12

**Figure E.3 – Example on insertion loss from Table E.1**

## Annex F (normative)

### Small wind turbines

#### F.1 General

Along with the development of larger wind turbines there is a development of small low-cost wind turbines. Due to the lower production cost as well as the different design it is found appropriate to ease the demands on the noise measurement for these wind turbines.

This annex describes the method for noise measurements on small low-cost wind turbines. The method can be used only for wind turbines with a maximum power output less than 100 kW.

The method in this annex deviates from the general method in the main body of the standard to better address the dynamic character of small wind turbines (e.g. free yaw, greater rotor speed variations). It also removes requirements that specifically address large turbines such as nacelle anemometry. The noise from wind turbines can either be determined according to the general method or according to this annex depending on the turbine configuration.

This annex follows the principles of the general method. The annex describes the deviations from the general method.

If a wind turbine is designed to run unloaded (e.g. if the battery is full, in a battery charging application) this situation should be included in the measurements and reported separately.

#### F.2 Acoustic measurement positions

Acceptable measurements shall not be more than  $\pm 45^\circ$  relative to the downwind microphone position and may be determined by wind direction measurements.

#### F.3 Wind speed measurements

Wind speed shall be measured directly instead of derived from electric power.

If a site assessment has been done in accordance with IEC 61400-12-1 to determine valid measurement sectors, data from the valid measurement sectors may be used. If no site assessment has been done then the meteorological tower shall be placed in accordance with Figure F.1, using  $\beta = 90^\circ$ .

The wind speed is determined from an anemometer which shall be placed at a height of least 10 m and preferably at rotor centre height. The distance between rotor centre and anemometer height shall be less than 25 m.

The wind speed shall be normalised to standard meteorological conditions as described in Equation (F.1) and adjusted to hub height applying the reference roughness length as described in Equation (F.2).

$$V_{Z,n} = V_{Z,m} \cdot \left( \frac{p}{T_k} \cdot \frac{T_{\text{ref}}}{p_{\text{ref}}} \right)^{1/3} \quad (\text{F.1})$$

where

- $V_{Z,m}$  is the measured wind speed at height  $Z$  averaged over 10 s;
- $T_k$  is the measured absolute air temperature averaged over 10 s;
- $p$  is the measured air pressure averaged over 10 s in kPa;
- $T_{ref}$  is the reference air temperature,  $T_0 = 288$  K;
- $p_{ref}$  is the reference air pressure,  $p_0 = 101,325$  kPa.

$$V_{H,n} = V_{Z,n} \cdot \left( \frac{\ln\left(\frac{H}{z_0}\right)}{\ln\left(\frac{z}{z_0}\right)} \right) \tag{F.2}$$

where

- $H$  is the hub height;
- $z$  is the measurement height for the wind speed;
- $z_0$  is the apparent roughness length.

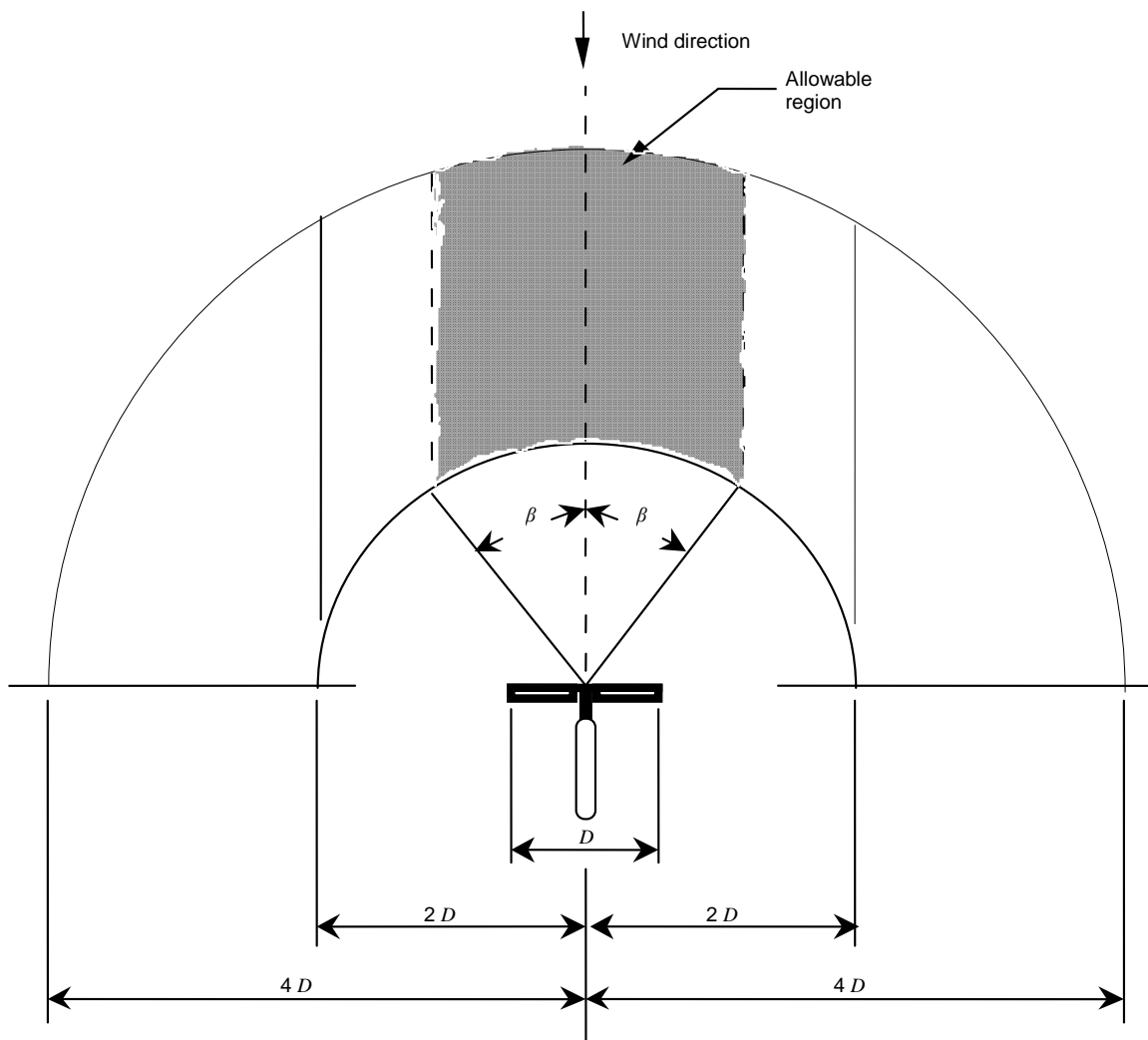

IEC 2106/12

**Figure F.1 – Allowable region for meteorological mast position as a function of  $\beta$  – Plan view**

## F.4 Wind speed range

The required wind speed range is from cut-in wind speed to 11 m/s as a minimum. Data should cover up to cut-out wind speed if possible, particularly for turbines that have speed control mechanisms.

The data shall be sorted into wind speed bins, 1 m/s wide, centred on integer wind speeds.

## F.5 Tonal Audibility

The general methodology will be followed with the exception of determination of tonal audibility.

For each integer wind speed, at least twelve 10 s spectra of A-weighted wind turbine noise are required. These 12 spectra shall be as close as possible to the integer wind speeds. If the A-weighting cannot be applied during measurement, linear spectra may be converted to A-weighted spectra according to IEC 61672-1:2002.

The tonality is analysed according to the method in 9.5.

If no tone was identified according to 9.5.4 for some of the twelve 10 s spectra so that  $\Delta L_{tn,j,k}$  is undefined, it shall be replaced by the following value:

$$\Delta L_{tn,j,k} = -10 \log \left[ \frac{\text{Critical bandwidth}}{\text{Effective noise bandwidth}} \right] \quad (\text{F.3})$$

The overall tonality,  $\Delta L_k$ , is determined as the energy average of the 12 individual  $\Delta L_{tn,j,k}$ .

## F.6 Information to be reported

The report shall contain the information described in Clause 10. Measurements and reporting of measured power, rotor rpm, pitch angle, yaw direction are not mandatory.

For small wind turbines an immission map based on the determined sound power levels shall be reported. The immission map shall cover the wind speed range for which reportable sound power levels are available. On the horizontal axis, the minimal value shall be the tower height of the test turbine and the maximum value shall be chosen such that a representative part of the 35 dB(A) contour line is showing. The sound pressure levels shall be calculated using spherical spreading. Sound pressure contours shall be drawn for multiples of 5 dB (e.g. 30 dB(A), 35 dB(A), 40 dB(A) and 45 dB(A)). Note that the immission map does not include penalties for tonality or similar as penalties are subject to local regulations. If penalties from local regulations are included in the immission map a statement of this shall follow the map.

If no data is available for a single wind speed bin, that data can be interpolated between neighboring bins. Interpolated data shall be distinguishable from actual data in the map either by using a different line style or by adding a statement under the map (e.g. "Immission levels at 7 m/s are based on interpolated data")

Figure F.2 shows an example of an immission map.

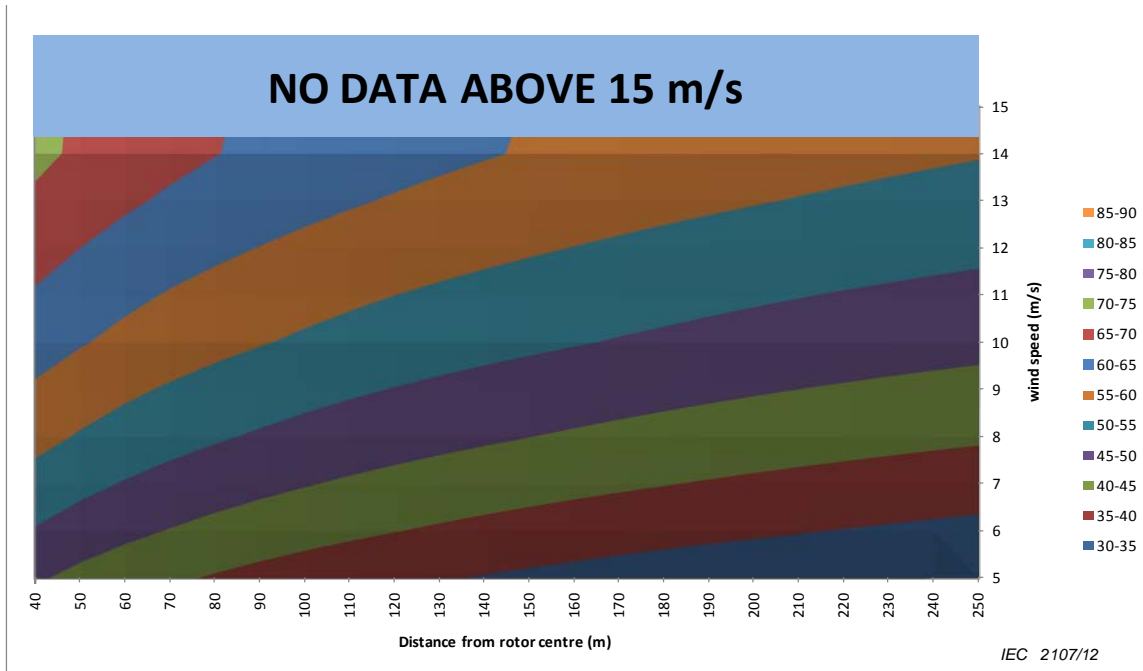

Figure F.2 – Example immission noise map

## Annex G (informative)

### Air absorption

With the increasing size of wind turbines the distance,  $R_1$ , to the reference point for the noise measurements is becoming larger and the air absorption may have an influence on the results of the measurements.

The air absorption is well defined for various meteorological conditions (e.g. ISO 9613-1:1993, *Acoustics – Attenuation of sound during propagation outside – Part 1: Calculation of the absorption of sound by the atmosphere*).

The sound attenuation coefficients of high frequencies can – depending on the air temperature, humidity and the distance to the noise source – amount to considerable values. High frequency noise of modern wind turbines is mostly radiated from the rotor blades. In the last years there was a very high focus on the development of the blade design, particularly the tip of the blade, to reduce the noise emission. This means that the distance of the measured total noise at high frequencies is usually low compared to the background noise during the measurement (see Figure G.1). Consequently, a background noise correction is not reliable for every 1/3-octave band and a possible correction for the air absorption would lead to an overestimation as it would be applied to background noise and not to the turbine noise only.

According to the data reduction procedure the background noise correction is leading to conservative sound pressure levels for the turbine noise, if the distance between total noise and background noise is small. As this approach is leading to higher sound power levels and a correction for the air absorption has a considerable uncertainty, it is recommended not to correct for the air absorption.

To minimise the effect of the air absorption the tolerance for the reference position is limited to  $\pm 30$  m and especially for large wind turbines it is recommended to choose a microphone position close to the turbine.

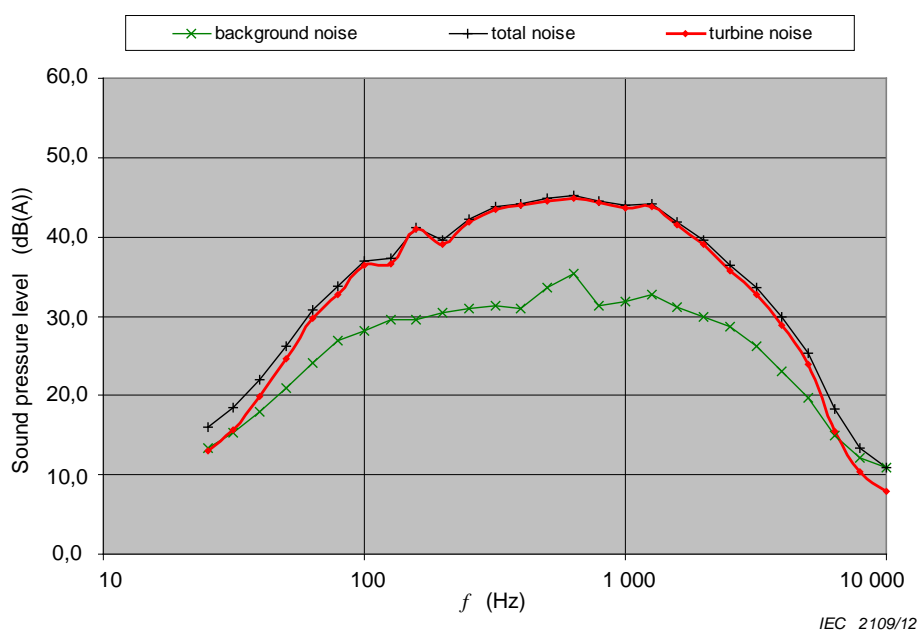

IEC 2109/12

Figure G.1 – Example of 1/3-octave spectrum

## Bibliography

ISO 7196, *Acoustics – Frequency-weighting characteristic for infrasound measurements*

IEC/TS 61400-14, *Wind turbines – Part 14: Declaration of apparent sound power level and tonality values*

ISO 9613-1:1993, *Acoustics – Attenuation of sound during propagation outside – Part 1: Calculation of the absorption of sound by the atmosphere*

---



INTERNATIONAL  
ELECTROTECHNICAL  
COMMISSION

3, rue de Varembé  
PO Box 131  
CH-1211 Geneva 20  
Switzerland

Tel: + 41 22 919 02 11  
Fax: + 41 22 919 03 00  
[info@iec.ch](mailto:info@iec.ch)  
[www.iec.ch](http://www.iec.ch)